

ITEM NO.	PART NUMBER	QTY.
1	stand	1
2	Press-core	1
3	Side_lifter	2

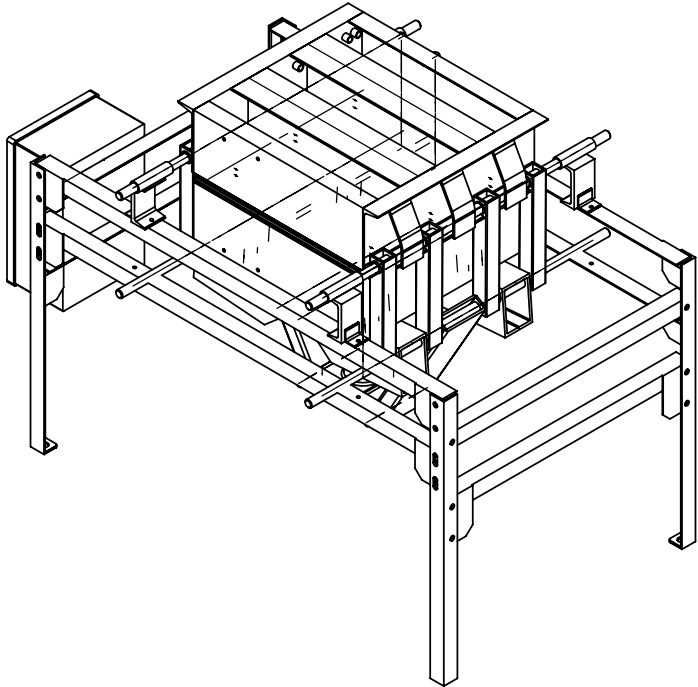

	NAME	DATE	Queen's University		
DRAWN	D. Matovic	2009/07/27			
CHECKED	D. Matovic	2009/07/27	TITLE:		
ENG APPR.			Kingston-hotpress		
MFG APPR.					
Q.A.					
COMMENTS:			SIZE	DWG. NO.	REV
Dimensions are in inches			A		
			SCALE: 1:50		SHEET 1 OF 1

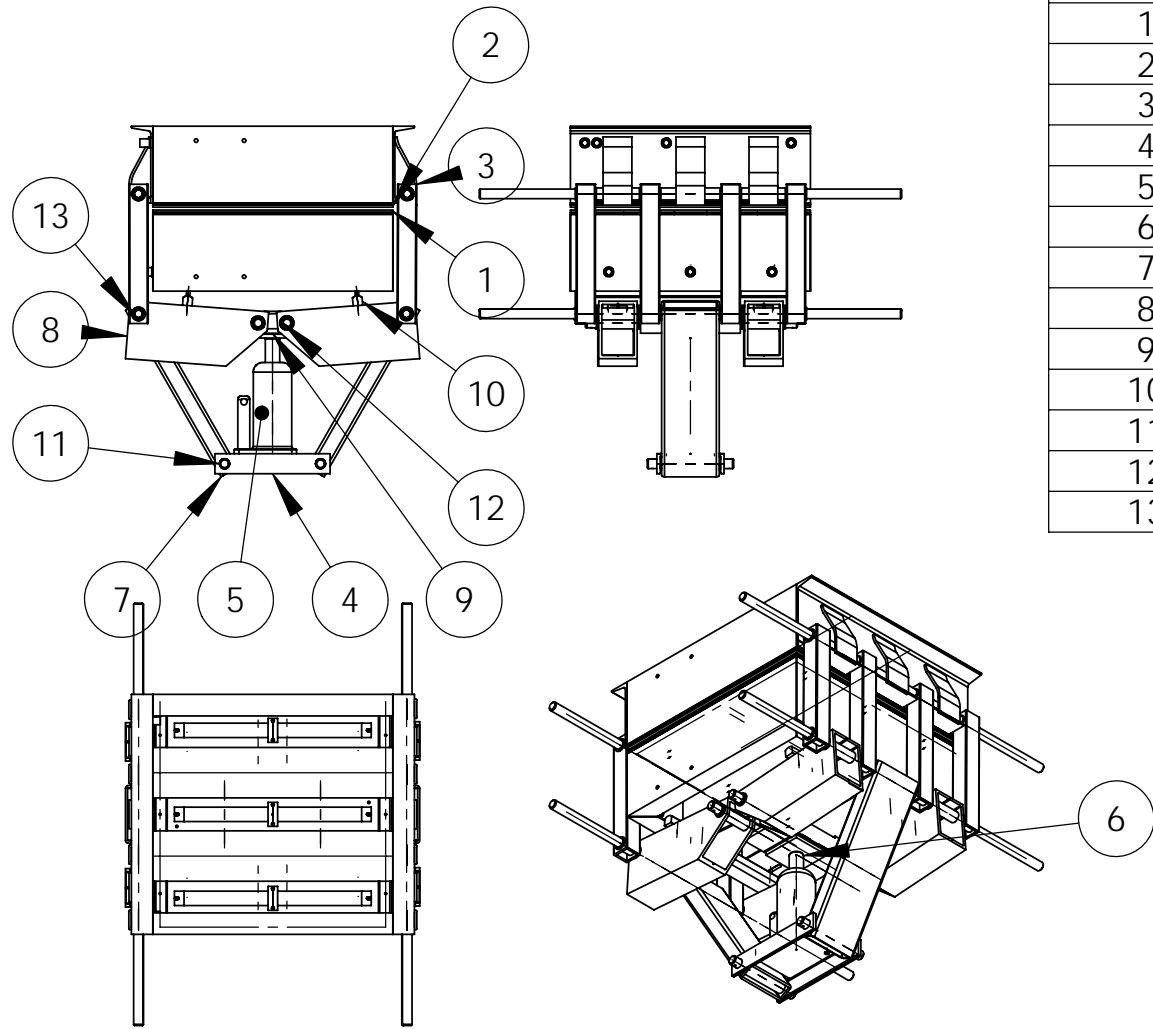



ITEM NO.	PART NUMBER	QTY.
1	bottom-leaf	1
2	Top-leaf	1
3	Main_link_2x2x0.25in	8
4	Jack_base_c7x9.8	1
5	hydraulic_jack_20tons	1
6	jack_stem	1
7	jack-holding-link	2
8	Leaver_2C6x10.5	4
9	Jack_top_Lifter	1
10	support_bar	2
11	pin_short	2
12	pin_medium	2
13	pin_long	4

	NAME	DATE	Queen's University		
DRAWN	D. Matovic	2009/07/27			
CHECKED	D. Matovic	2009/07/27	TITLE: Press-core		
ENG APPR.					
MFG APPR.					
Q.A.					
COMMENTS: Dimensions are in inches			SIZE A	DWG. NO.	REV
			SCALE: 1:20		SHEET 1 OF 1

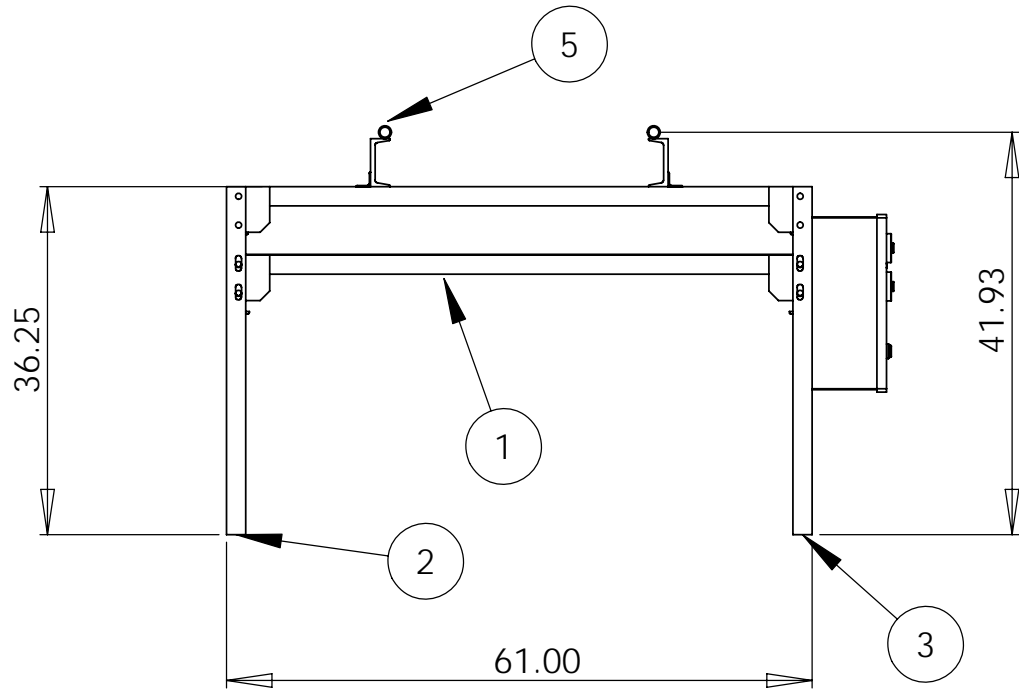
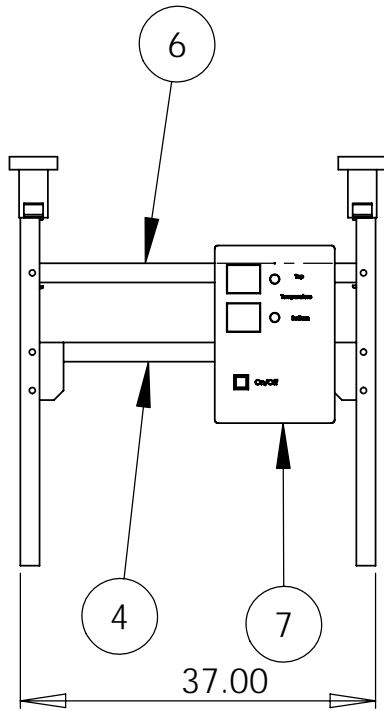

ITEM NO.	PART NUMBER	QTY.
1	Stand_side_long_L2x2x0.25in	4
2	leg_left	2
3	leg_right	2
4	Stand_side_short_L2x2x0.25in	2
5	Top-pin-seat	4
6	Stand_side_short_L2x2x0.25in_no_pegs	2
7	Control_Panel	1

		NAME	DATE	Queen's University		
DRAWN		D. Matovic	2009/07/27	TITLE: stand		
CHECKED		D. Matovic	2009/07/27			
ENG APPR.						
MFG APPR.						
Q.A.						
COMMENTS: Dimensions are in inches				SIZE A	DWG. NO.	REV
				SCALE: 1:50		SHEET 1 OF 1

5

↑

4

3

2

1

ITEM NO.	PART NUMBER	QTY.
1	Top-weldment	1
2	Gasket-top-one-piece	1
3	Plate_with_heaters	1
4	connector_1_in	4

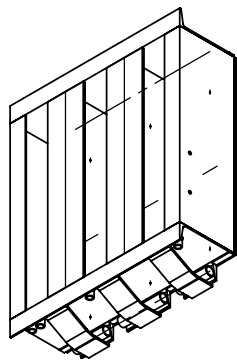
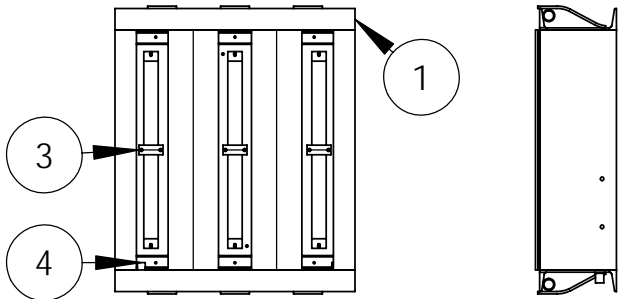
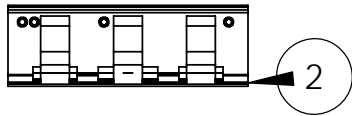

	NAME	DATE	Queen's University		
DRAWN	D. Matovic	2009/07/27			
CHECKED	D. Matovic	2009/07/27	TITLE:		
ENG APPR.			Top-leaf		
MFG APPR.					
Q.A.					
COMMENTS:			SIZE	DWG. NO.	REV
Dimensions are in inches			A		
			SCALE: 1:20		SHEET 1 OF 1

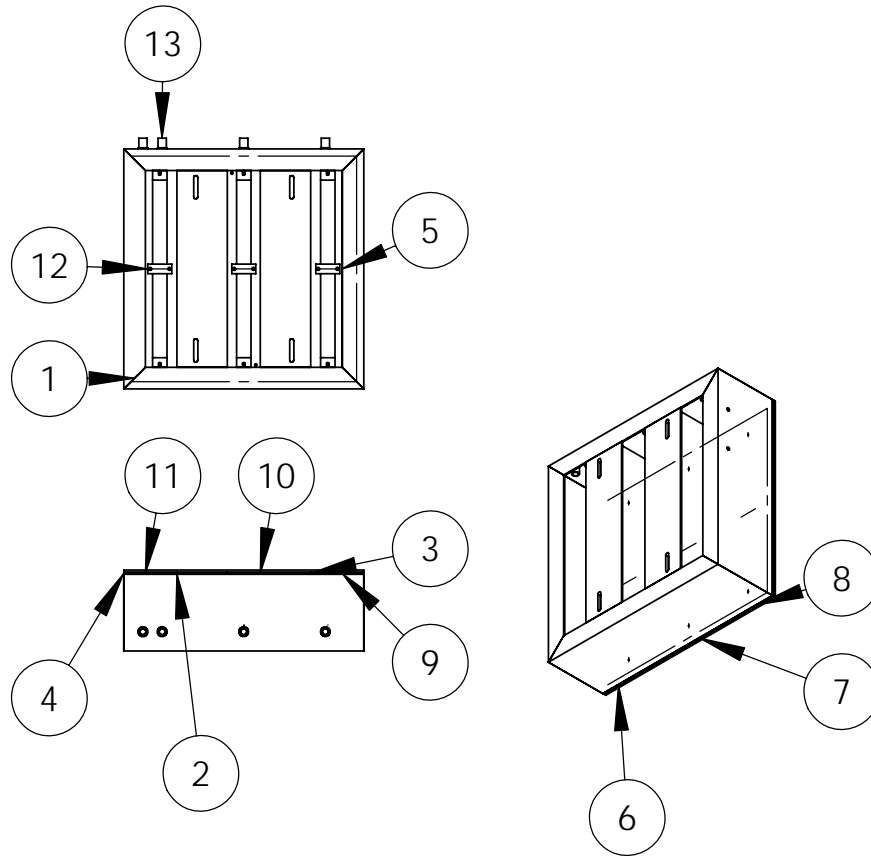

ITEM NO.	PART NUMBER	QTY.
1	Bottom-weldment	1
2	Gasket-bottom-centre-left	1
3	Gasket-bottom-centre-right	1
4	Gasket-bottom-left	1
5	Gasket-bottom-right	1
6	Gasket-bottom-upper-left	1
7	Gasket-bottom-upper-centre	1
8	Gasket-bottom-upper-right	1
9	Gasket-bottom-lower-right	1
10	Gasket-bottom-lower-centre	1
11	Gasket-bottom-lower-left	1
12	Plate_with_heaters	1
13	connector_1_in	4

		NAME	DATE	Queen's University		
DRAWN		D. Matovic	2009/07/27			TITLE: bottom-leaf
CHECKED		D. Matovic	2009/07/27			
ENG APPR.						
MFG APPR.						
Q.A.						
COMMENTS: Dimensions are in inches				SIZE A	DWG. NO.	REV
				SCALE: 1:20		SHEET 1 OF 1

ITEM NO.	PART NUMBER	QTY.
1	plate	1
2	Strip_heater	3
3	bracket	3

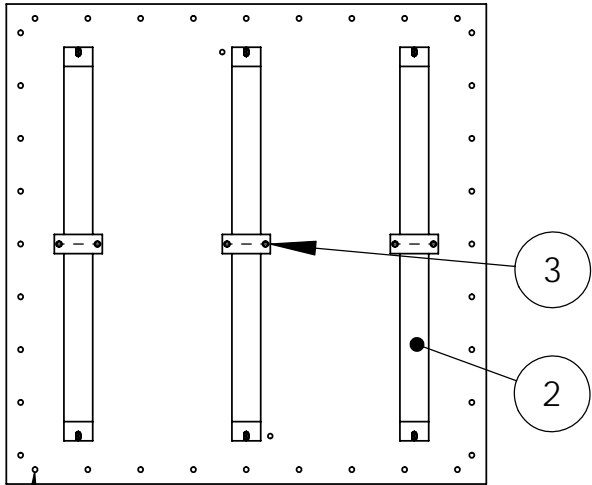

		NAME	DATE	Queen's University	
DRAWN	D. Matovic	2009/07/27	TITLE:		
CHECKED	D. Matovic	2009/07/27	Plate_with_heaters		
ENG APPR.					
MFG APPR.					
Q.A.					
COMMENTS:			SIZE	DWG. NO.	REV
Dimensions are in inches			A		
			SCALE: 1:10		SHEET 1 OF 1

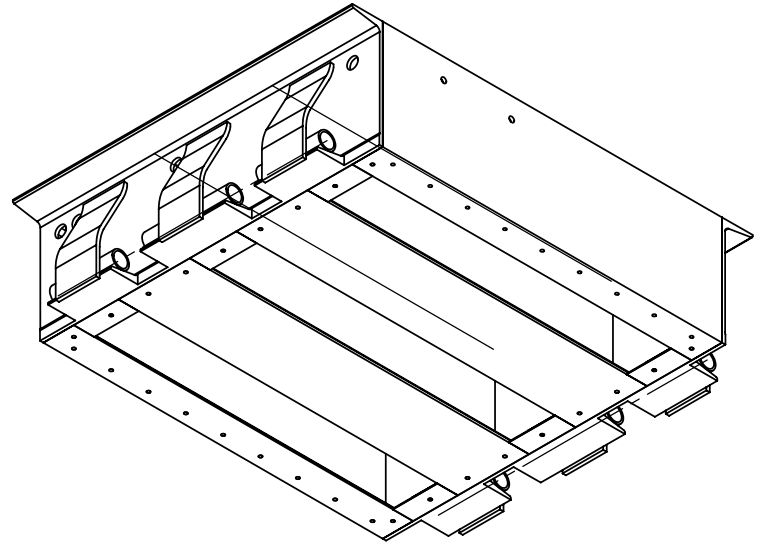
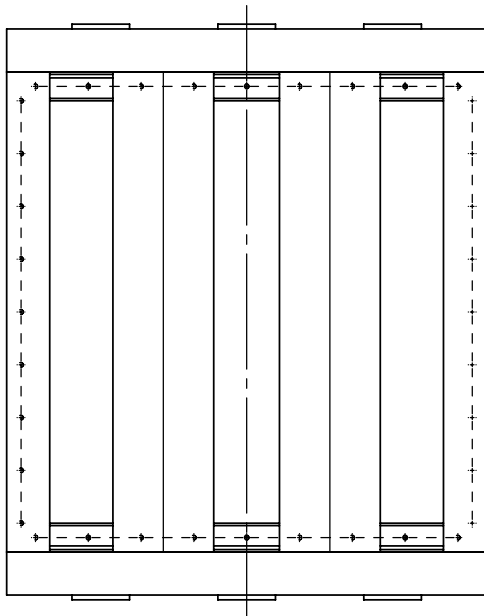
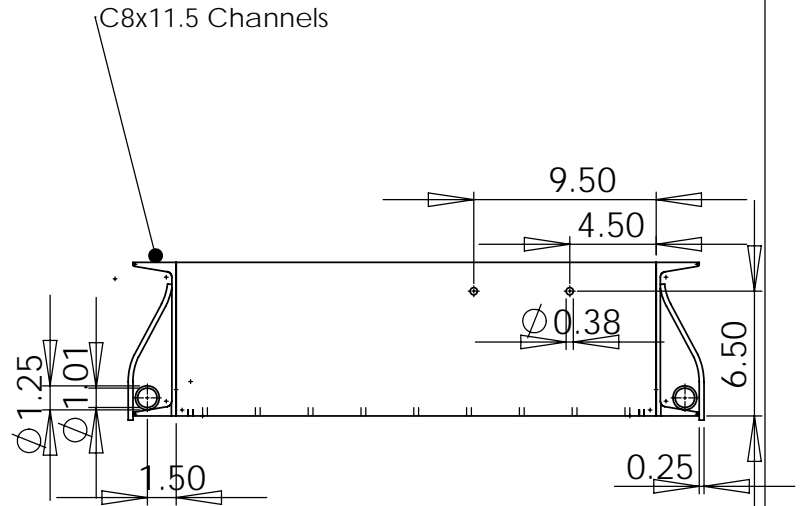
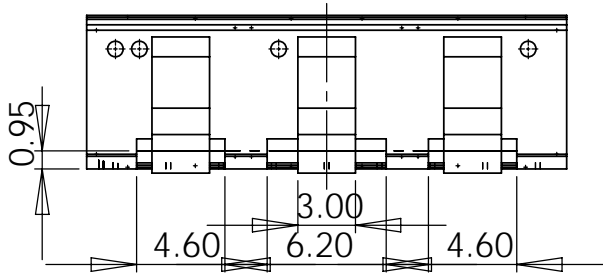
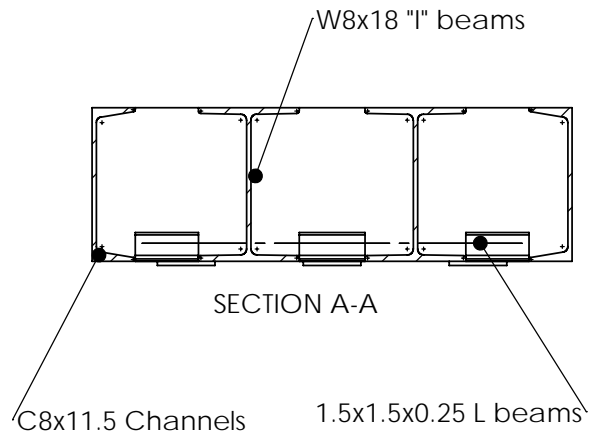
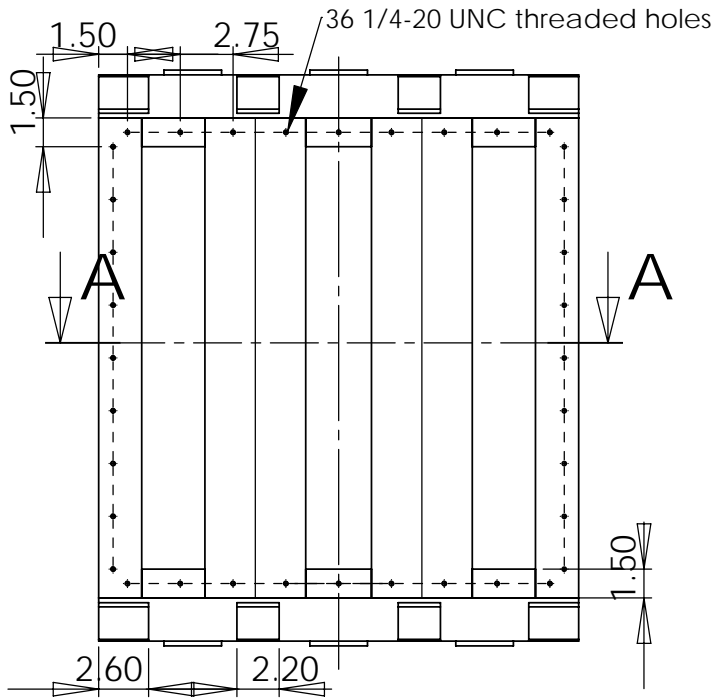

	NAME	DATE
DRAWN	D. Matovic	2009/07/27
CHECKED	D. Matovic	2009/07/27
ENG APPR.		
MFG APPR.		
Q.A.		

COMMENTS:
Dimensions are in inches

Queen's University

Top-weldment

SIZE	DWG. NO.	REV.
A		
SCALE:1:10		SHEET 1 OF 1

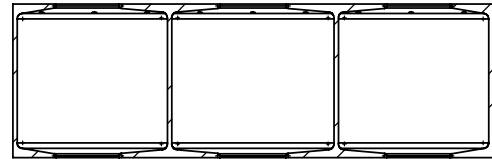
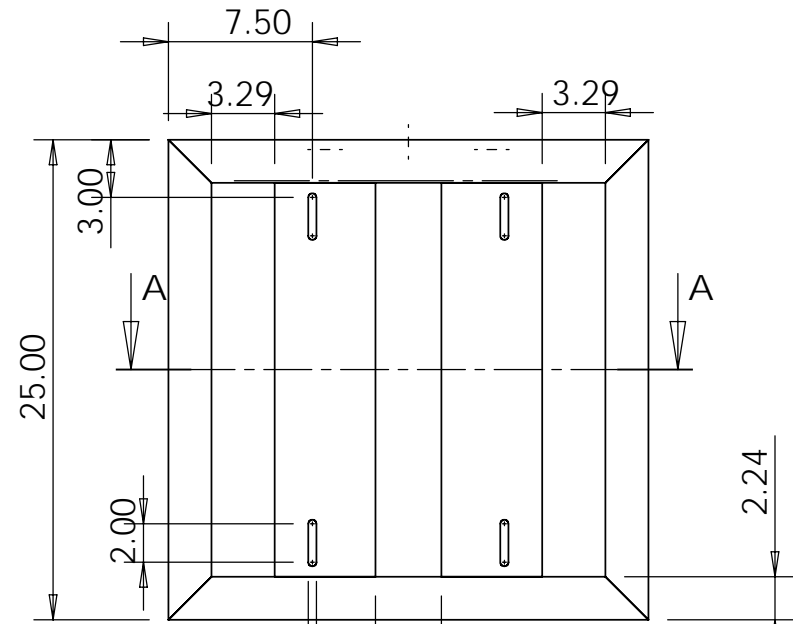

SECTION A-A

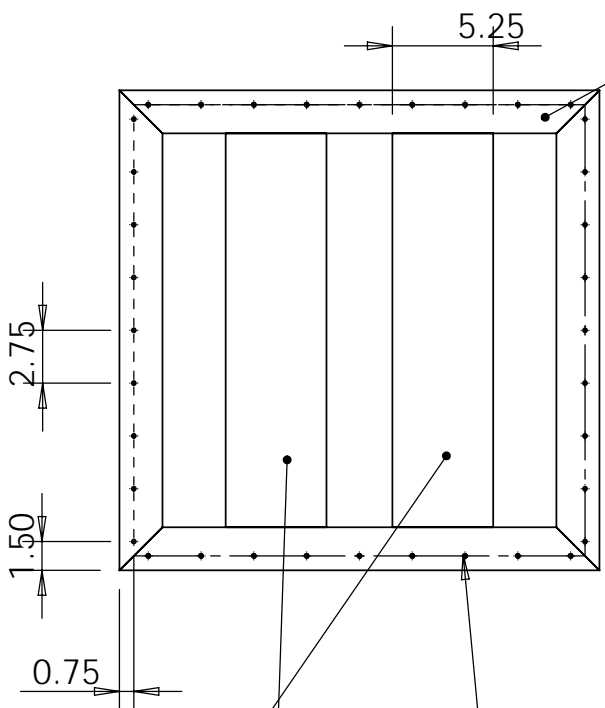
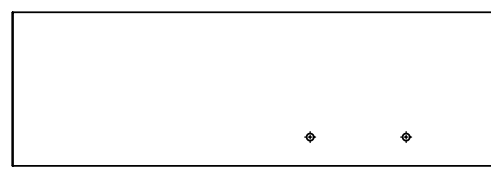
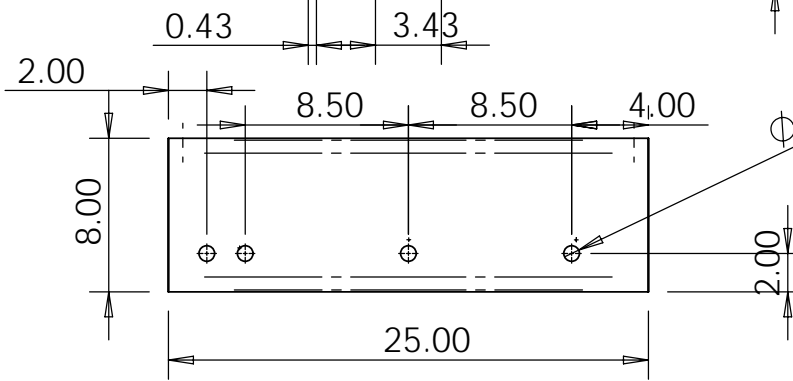

C8x11.5 Channels

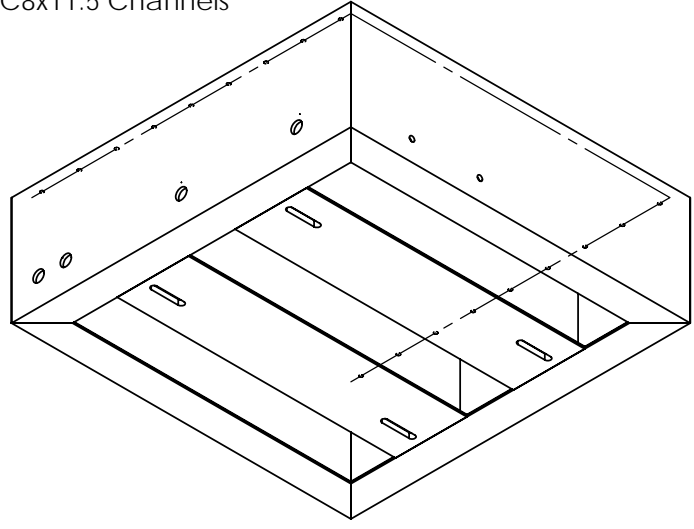

W8x18 "I" Beams

36 1/4-20 UNC threaded holes

	NAME	DATE
DRAWN	D. Matovic	2009/07/27
CHECKED	D. Matovic	2009/07/27
ENG APPR.		
MFG APPR.		
Q.A.		

COMMENTS:
Dimensions are in inches

Queen's University

Bottom-weldment

SIZE	DWG. NO.	REV.
A		

SCALE: 1:10 WEIGHT: ERROR! Weight ERROR! Weight SHEET 1 OF 1

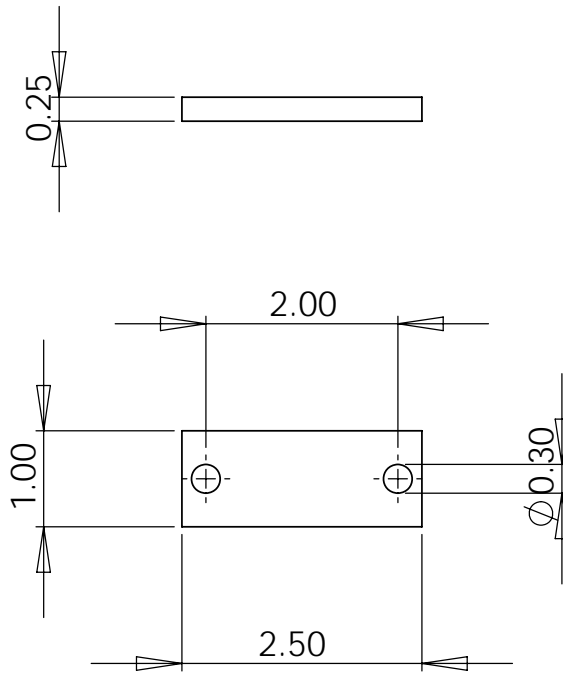

	NAME	DATE	Queen's University		
DRAWN	D. Matovic	2009/07/27			
CHECKED	D. Matovic	2009/07/27	Bracket		
ENG APPR.					
MFG APPR.					
Q.A.					
COMMENTS:			SIZE	DWG. NO.	REV.
Dimensions are in inches			A		
			SCALE:1:10		SHEET 1 OF 1

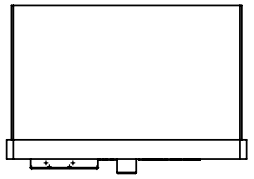
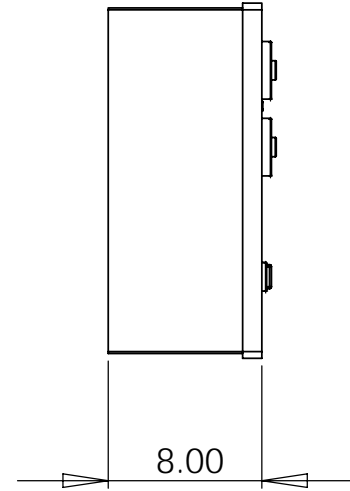
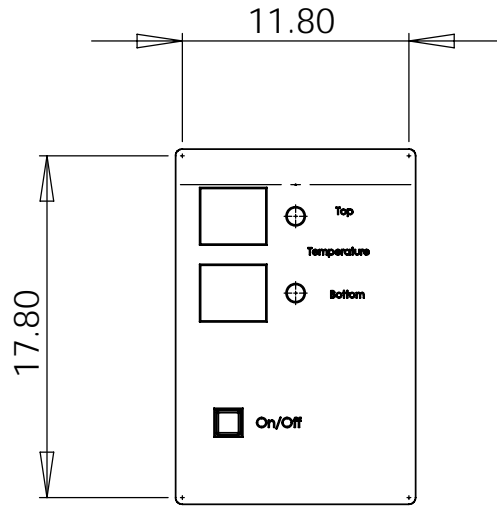

	NAME	DATE	Queen's University		
DRAWN	D. Matovic	2009/07/27			
CHECKED	D. Matovic	2009/07/27	TITLE: Control_Panel		
ENG APPR.					
MFG APPR.					
Q.A.					
COMMENTS: Dimensions are in inches			SIZE A	DWG. NO.	REV
			SCALE: 1:10		SHEET 1 OF 1

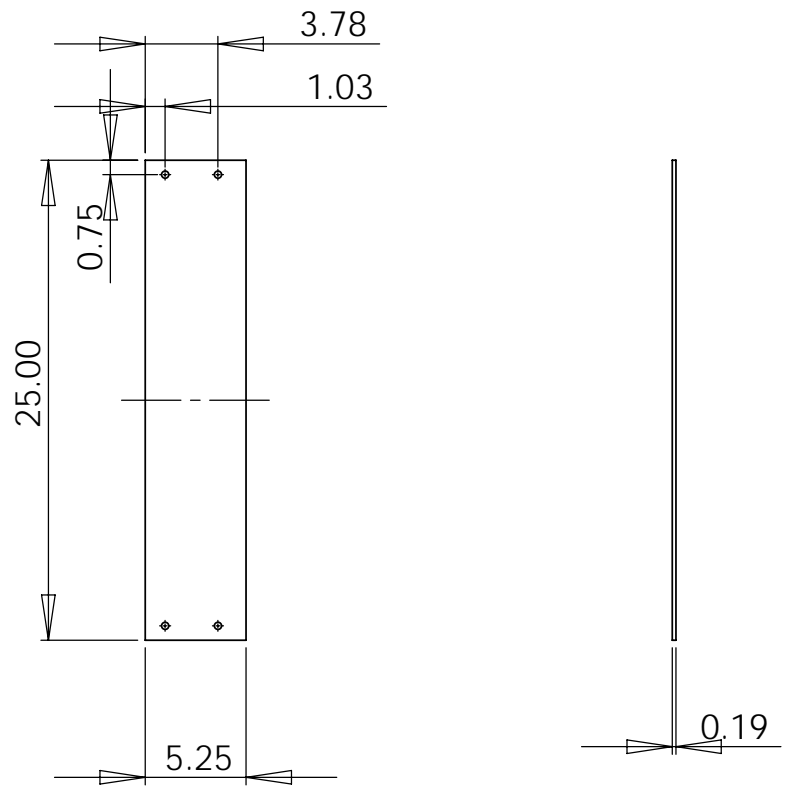

	NAME	DATE	Queen's University		
DRAWN	D. Matovic	2009/07/27			
CHECKED	D. Matovic	2009/07/27	Gasket-bottom-centre-left		
ENG APPR.					
MFG APPR.					
Q.A.					
COMMENTS:			SIZE	DWG. NO.	REV.
Dimensions are in inches			A		
			SCALE:1:10	Material: Cork-rubber	SHEET 1 OF 1

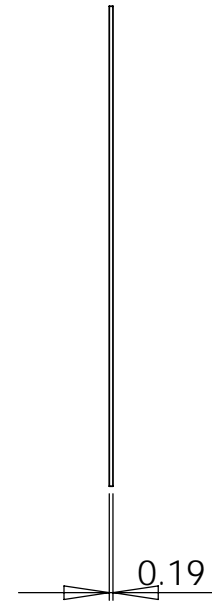
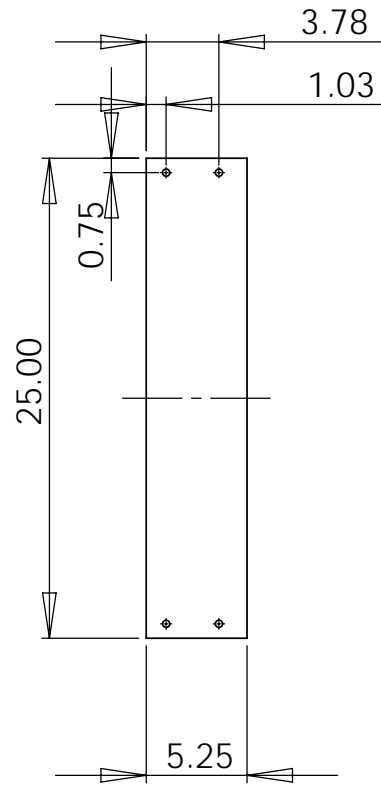

	NAME	DATE	Queen's University
DRAWN	D. Matovic	2009/07/27	
CHECKED	D. Matovic	2009/07/27	
DATE			

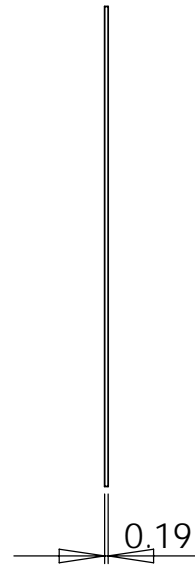
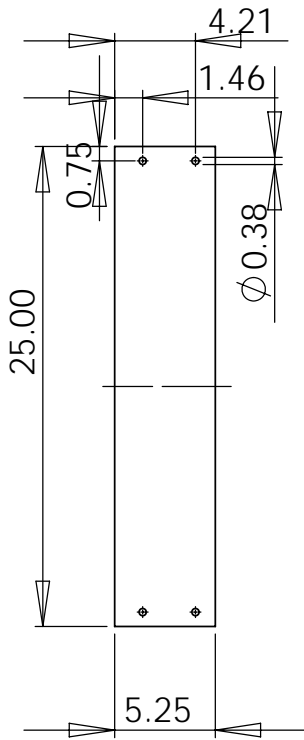

	NAME	DATE	Queen's University		
DRAWN	D. Matovic	2009/07/27			
CHECKED	D. Matovic	2009/07/27	Gasket-bottom-centre-right		
ENG APPR.					
MFG APPR.					
Q.A.					
COMMENTS:			SIZE	DWG. NO.	REV.
Dimensions are in inches			A		
			SCALE:1:10	Material: Cork-rubber	SHEET 1 OF 1

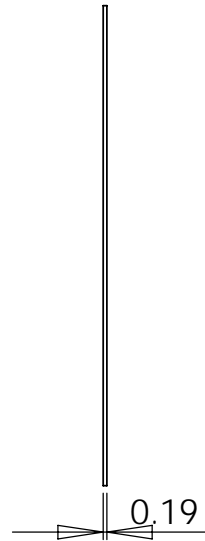
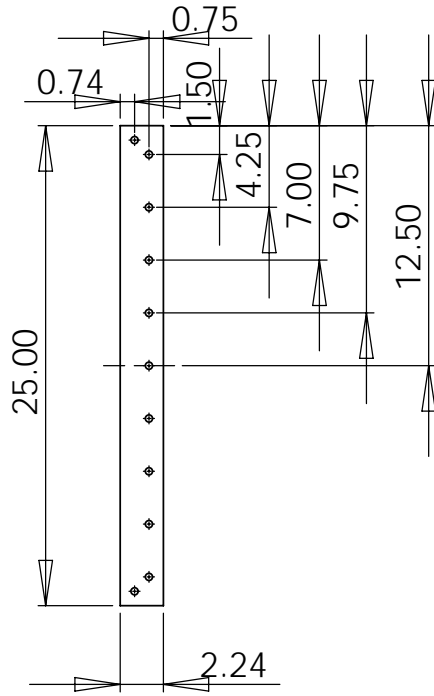

	NAME	DATE	Queen's University		
DRAWN	D. Matovic	2009/07/27	Gasket-bottom-left		
CHECKED	D. Matovic	2009/07/27			
ENG APPR.					
MFG APPR.					
Q.A.					
COMMENTS:			SIZE	DWG. NO.	REV.
Dimensions are in inches			A		
			SCALE:1:10	Material: Cork-rubber	SHEET 1 OF 1

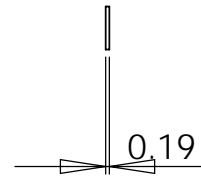
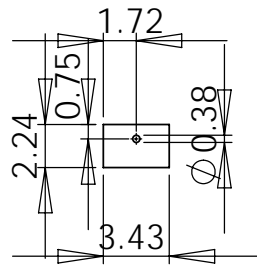

	NAME	DATE	Queen's University		
DRAWN	D. Matovic	2009/07/27			
CHECKED	D. Matovic	2009/07/27	Gasket-bottom-lower-centre		
ENG APPR.					
MFG APPR.					
Q.A.					
COMMENTS:					
Dimensions are in inches			SIZE	DWG. NO.	REV.
			A		
			SCALE: 1:10	Material: Cork-rubber	SHEET 1 OF 1

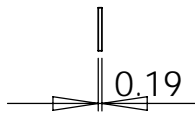
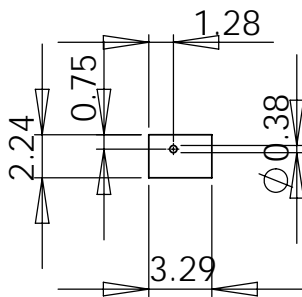

	NAME	DATE	Queen's University Gasket-bottom-lower-left		
DRAWN	D. Matovic	2009/07/27			
CHECKED	D. Matovic	2009/07/27			
ENG APPR.					
MFG APPR.					
Q.A.					
COMMENTS:					
Dimensions are in inches			SIZE	DWG. NO.	REV.
			A		
			SCALE:1:10	Material: Cork-rubber	SHEET 1 OF 1

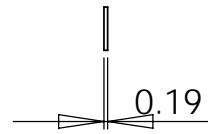
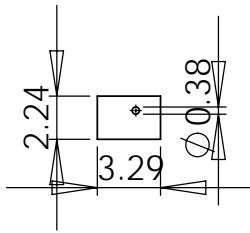

	NAME	DATE	Queen's University		
DRAWN	D. Matovic	2009/07/27			
CHECKED	D. Matovic	2009/07/27	Gasket-bottom-lower-right		
ENG APPR.					
MFG APPR.					
Q.A.					
COMMENTS:					
Dimensions are in inches			SIZE	DWG. NO.	REV.
			A		
			SCALE:1:10	Material: Cork-rubber	SHEET 1 OF 1

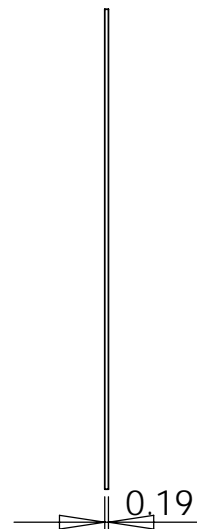
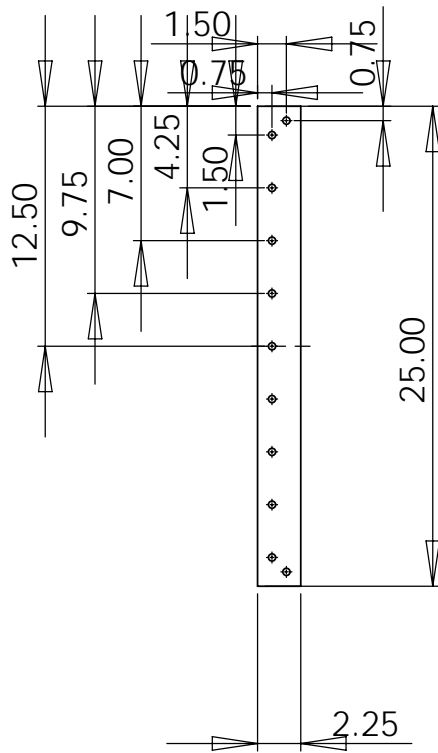

	NAME	DATE	Queen's University		
DRAWN	D. Matovic	2009/07/27			
CHECKED	D. Matovic	2009/07/27	Gasket-bottom-right		
ENG APPR.					
MFG APPR.					
Q.A.					
COMMENTS:			SIZE	DWG. NO.	REV.
Dimensions are in inches			A		
			SCALE:1:10	Material: Cork-rubber	SHEET 1 OF 1

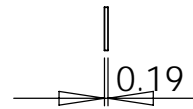
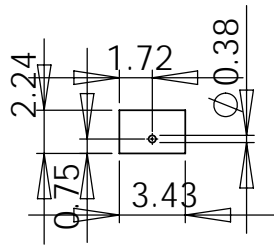

	NAME	DATE	Queen's University		
DRAWN	D. Matovic	2009/07/27			
CHECKED	D. Matovic	2009/07/27	Gasket-bottom-upper-centre		
ENG APPR.					
MFG APPR.					
Q.A.					
COMMENTS:			SIZE	DWG. NO.	REV.
Dimensions are in inches			A		
			SCALE:1:10	Material: Cork-rubber	SHEET 1 OF 1

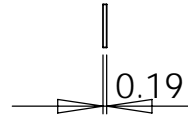
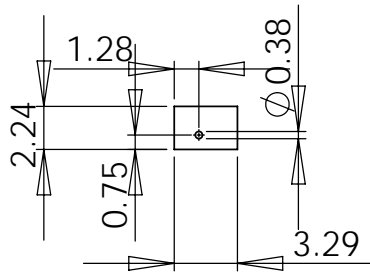

	NAME	DATE	Queen's University		
DRAWN	D. Matovic	2009/07/27			
CHECKED	D. Matovic	2009/07/27	Gasket-bottom-upper-left		
ENG APPR.					
MFG APPR.					
Q.A.					
COMMENTS:			SIZE	DWG. NO.	REV.
Dimensions are in inches			A		
			SCALE:1:10	Material: Cork-rubber	SHEET 1 OF 1

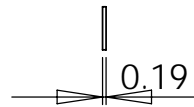
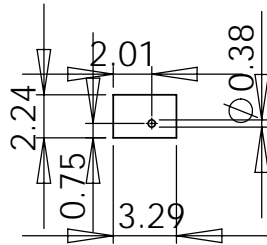

	NAME	DATE	Queen's University		
DRAWN	D. Matovic	2009/07/27			
CHECKED	D. Matovic	2009/07/27	Gasket-bottom-upper-right		
ENG APPR.					
MFG APPR.					
Q.A.					
COMMENTS:			SIZE	DWG. NO.	REV.
Dimensions are in inches			A		
			SCALE:1:10	Material: Cork-rubber	SHEET 1 OF 1

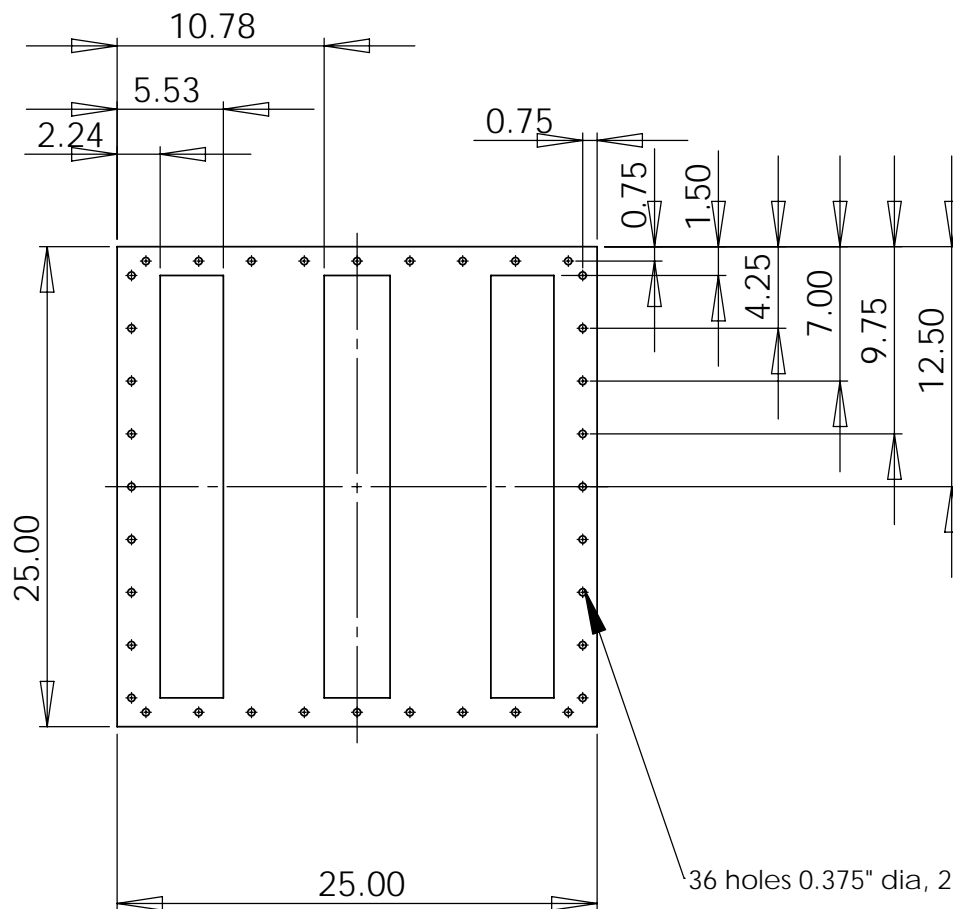

36 holes 0.375" dia, 2.75" apart

0.19

	NAME	DATE	Queen's University		
DRAWN	D. Matovic	2009/07/27			
CHECKED	D. Matovic	2009/07/27	Gasket-top-one-piece		
ENG APPR.					
MFG APPR.					
Q.A.					
COMMENTS:			SIZE	DWG. NO.	REV.
Dimensions are in inches			A		
			SCALE:1:10	Material: Cork-rubber	SHEET 1 OF 1

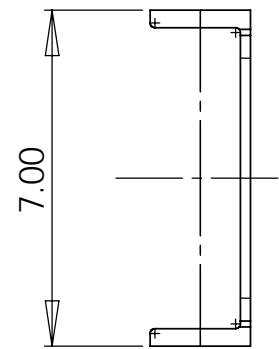
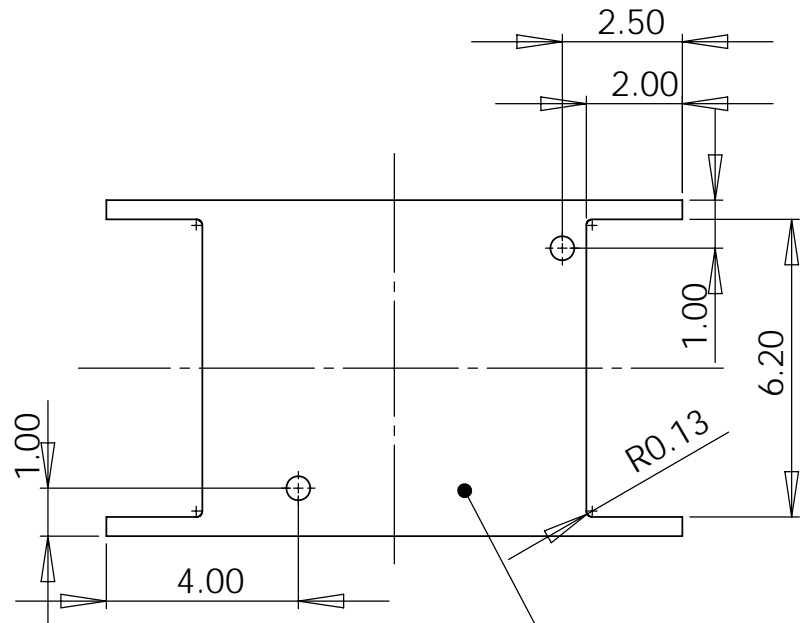
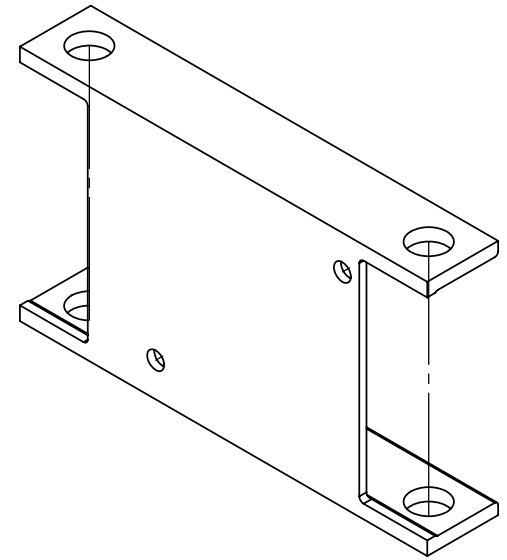
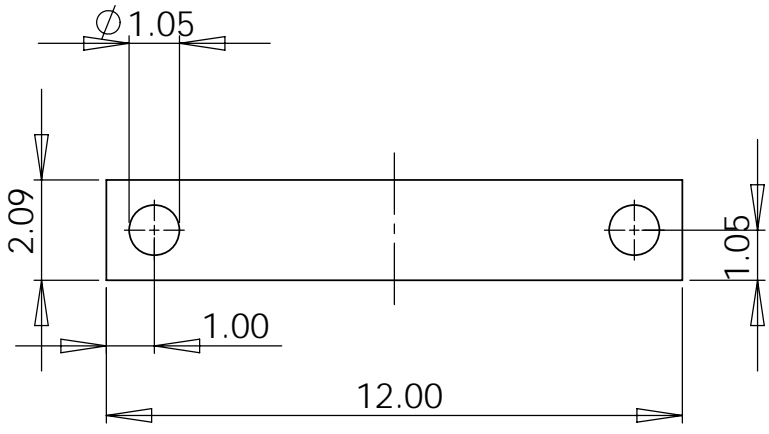

C7x9.8 C channel

	NAME	DATE	Queen's University		
DRAWN	D. Matovic	2009/07/27			
CHECKED	D. Matovic	2009/07/27	Jack_base_c7x9.8		
ENG APPR.					
MFG APPR.					
Q.A.					
COMMENTS:			SIZE	DWG. NO.	REV.
Dimensions are in inches			A		
			SCALE:1:10		SHEET 1 OF 1

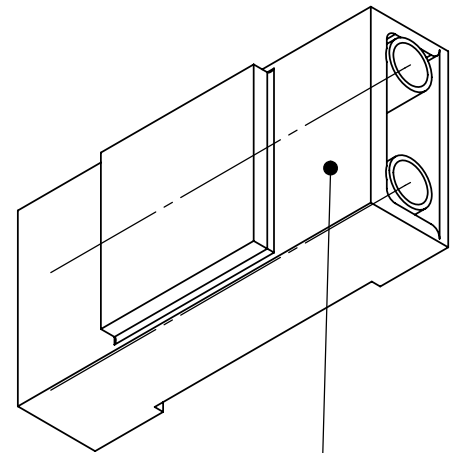
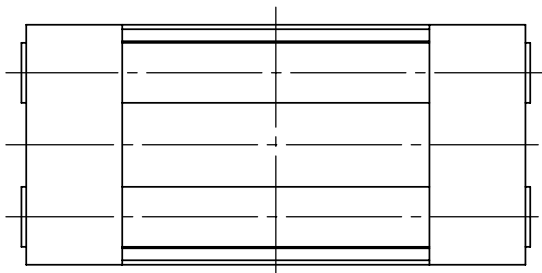
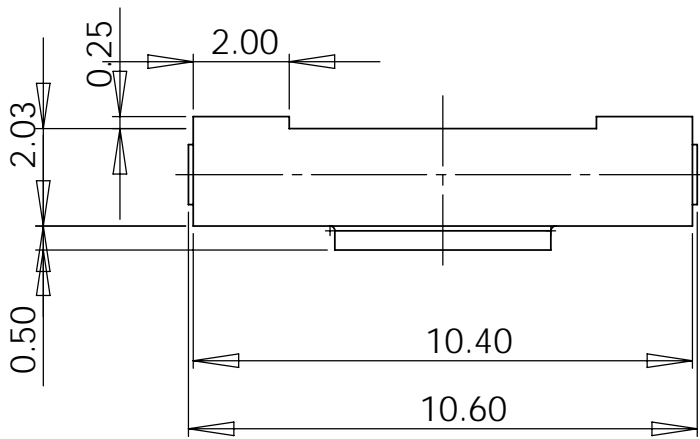
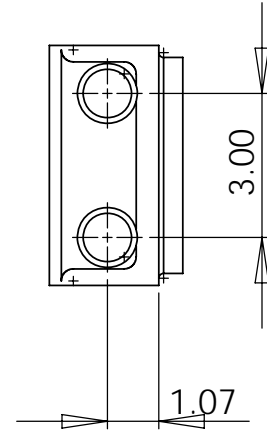
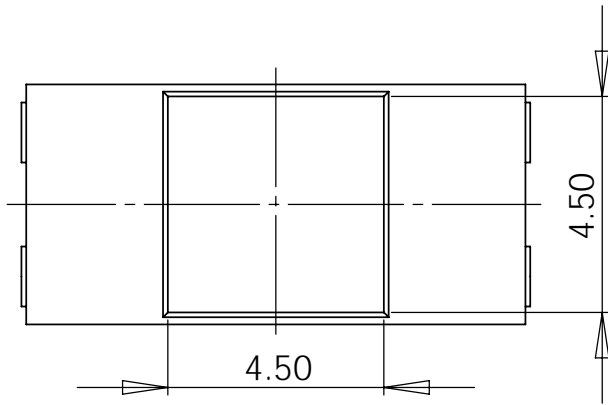

C5x11.5 Channel

	NAME	DATE	Queen's University		
DRAWN	D. Matovic	2009/07/27			
CHECKED	D. Matovic	2009/07/27	Jack_top_Lifter		
ENG APPR.					
MFG APPR.					
Q.A.					
COMMENTS:			SIZE	DWG. NO.	REV.
Dimensions are in inches			A		
			SCALE:1:4		SHEET 1 OF 1

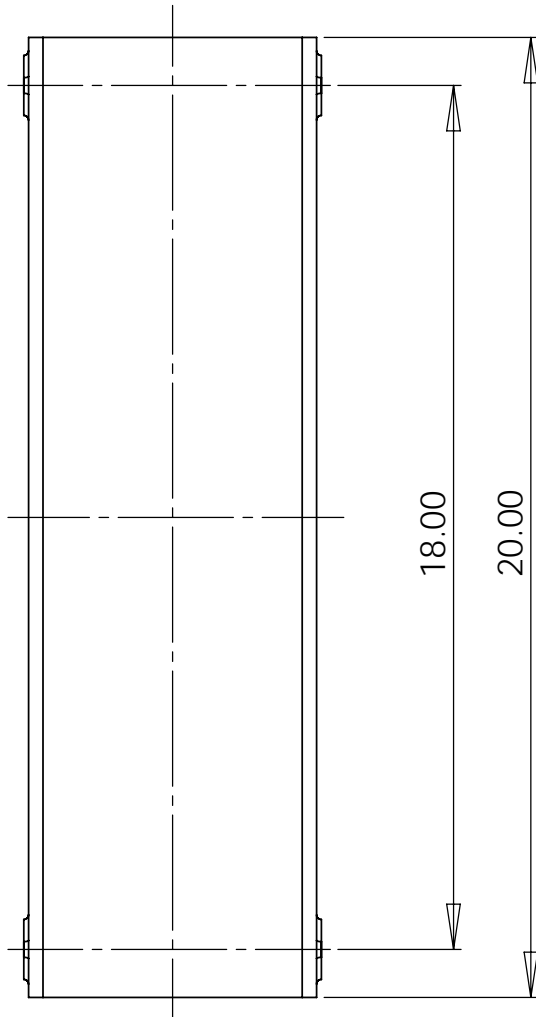
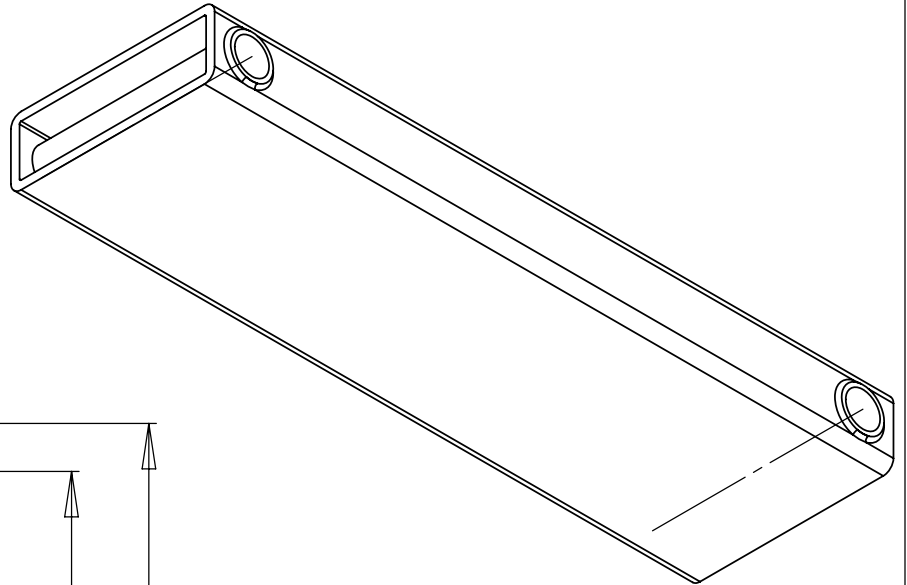
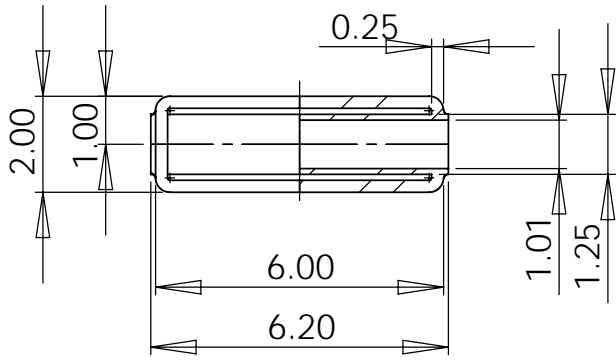

For placing and welding the pipe segments, drill 1-9/32" hole and countersink it, to make room for welding bead.

NAME		DATE	Queen's University		
DRAWN	D. Matovic	2009/07/27	jack-holding-link		
CHECKED	D. Matovic	2009/07/27			
ENG APPR.					
MFG APPR.					
Q.A.					
COMMENTS:			SIZE	DWG. NO.	REV.
Dimensions are in inches			A		
			SCALE:1:10		SHEET 1 OF 1

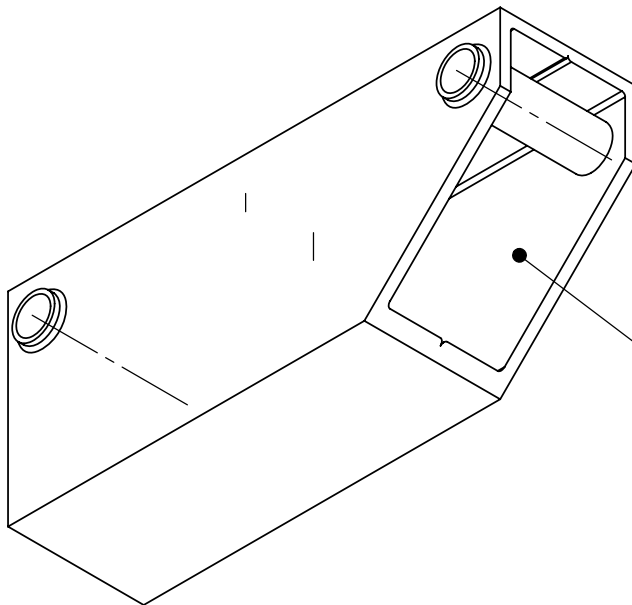
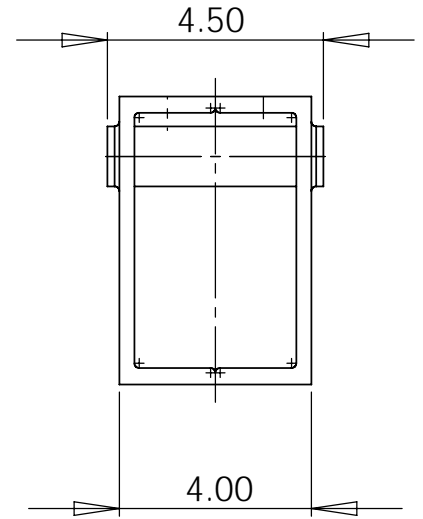
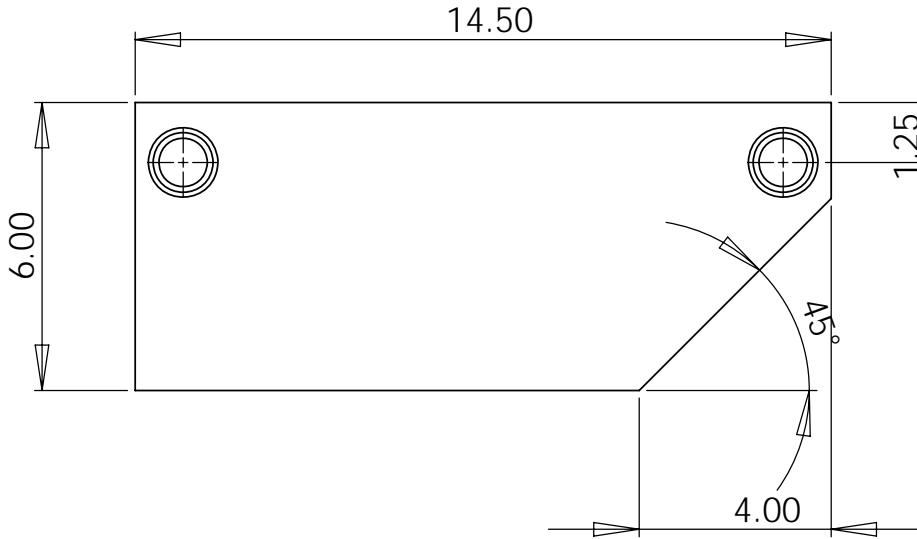
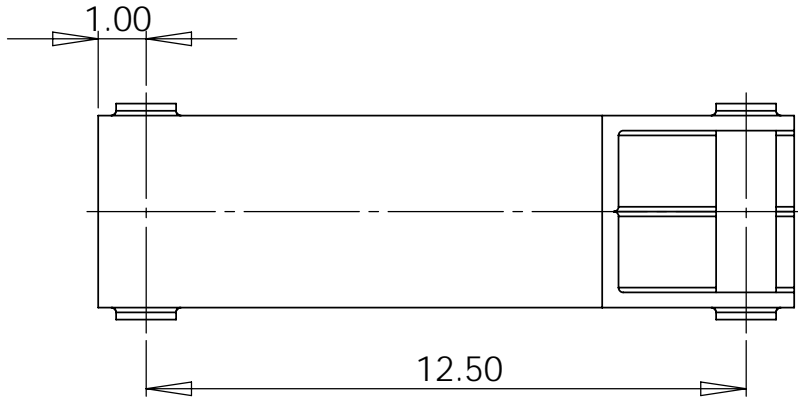

2 C6x10.5 Channels welded together

	NAME	DATE	Queen's University		
DRAWN	D. Matovic	2009/07/27	Leaver_2C6x10.5		
CHECKED	D. Matovic	2009/07/27			
ENG APPR.					
MFG APPR.					
Q.A.					
COMMENTS:			SIZE	DWG. NO.	REV.
Dimensions are in inches			A		
			SCALE:1:10	SHEET 1 OF 1	

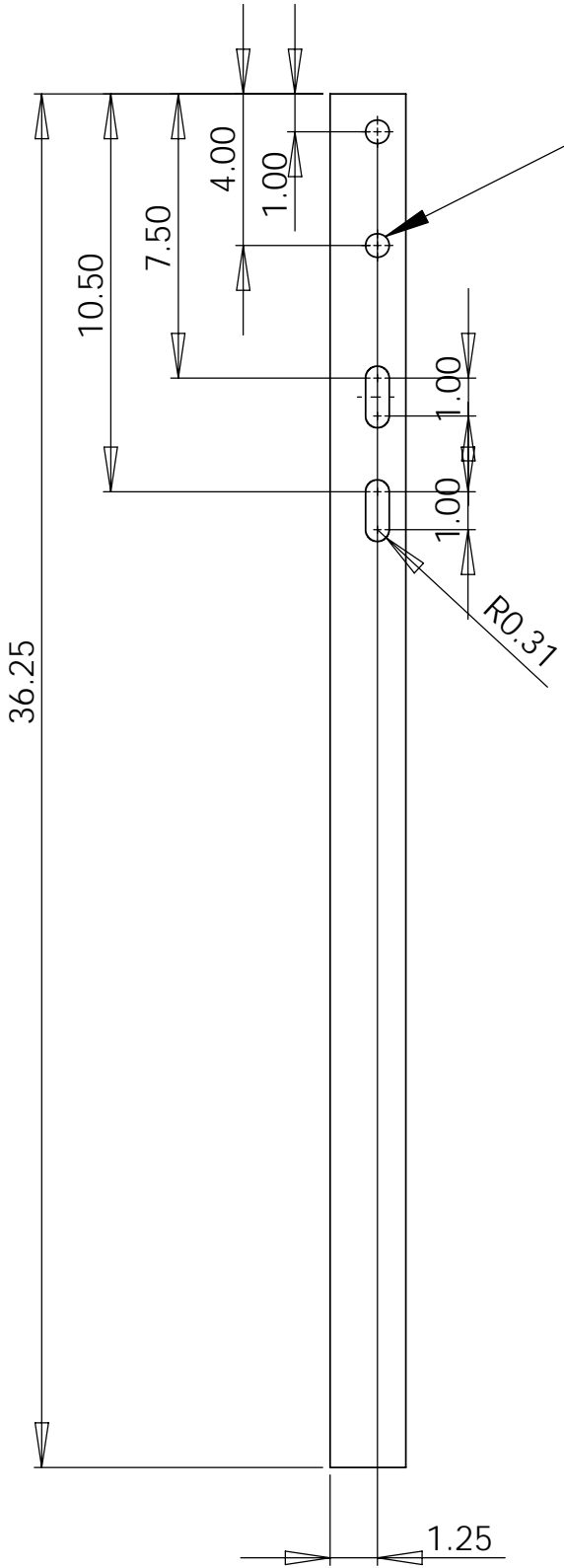

2x2x0.25 Angle profile

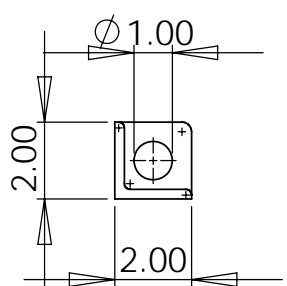
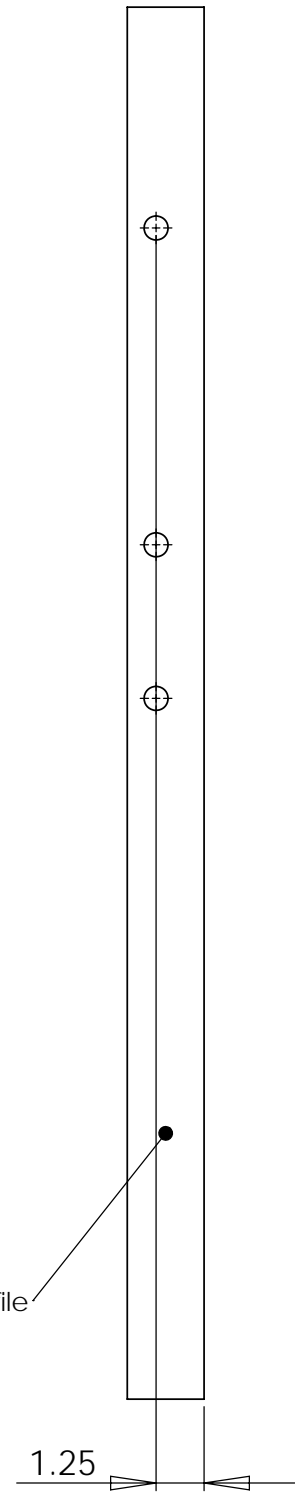

NAME		DATE	Queen's University	
DRAWN	D. Matovic	2009/07/27	leg_left	
CHECKED	D. Matovic	2009/07/27		
ENG APPR.				
MFG APPR.				
Q.A.				
COMMENTS:				
Dimensions are in inches			SIZE A	DWG. NO.
			SCALE:1:10	REV.
			SHEET 1 OF 1	

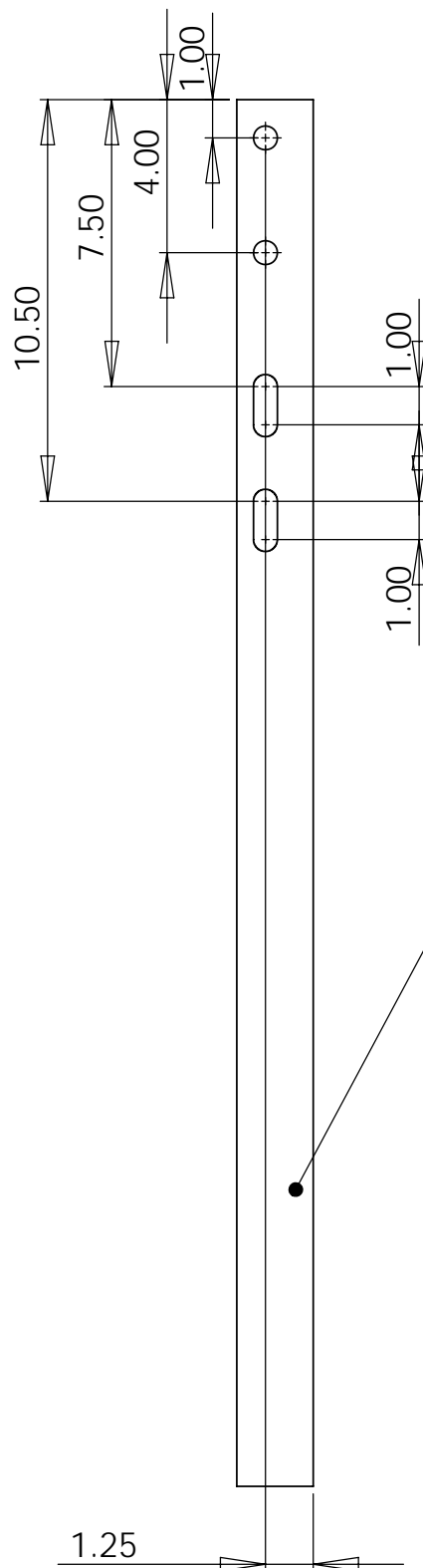
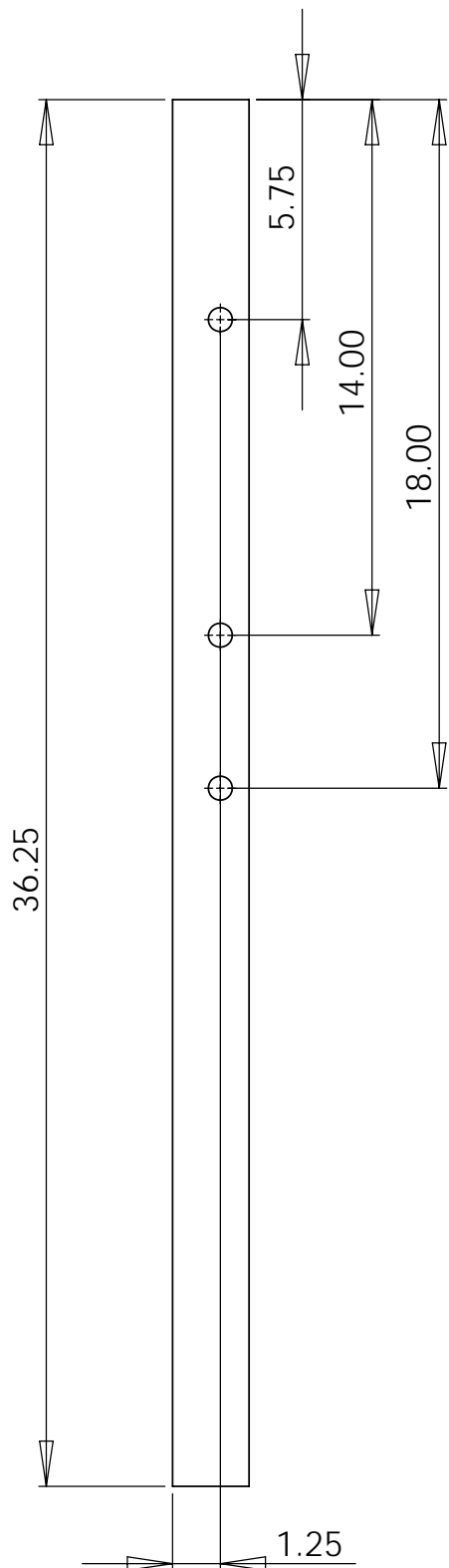

2x2x0.25 Angle profile

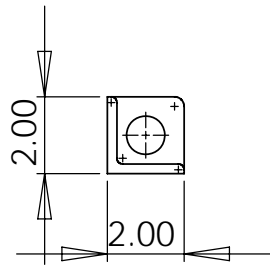

	NAME	DATE	Queen's University		
DRAWN	D. Matovic	2009/07/27	leg_right		
CHECKED	D. Matovic	2009/07/27			
ENG APPR.					
MFG APPR.					
Q.A.					
COMMENTS:			SIZE	DWG. NO.	REV.
Dimensions are in inches			A		
			SCALE:1:10	SHEET 1 OF 1	

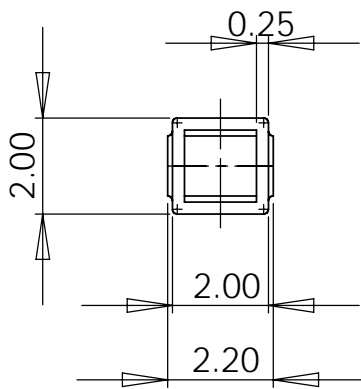
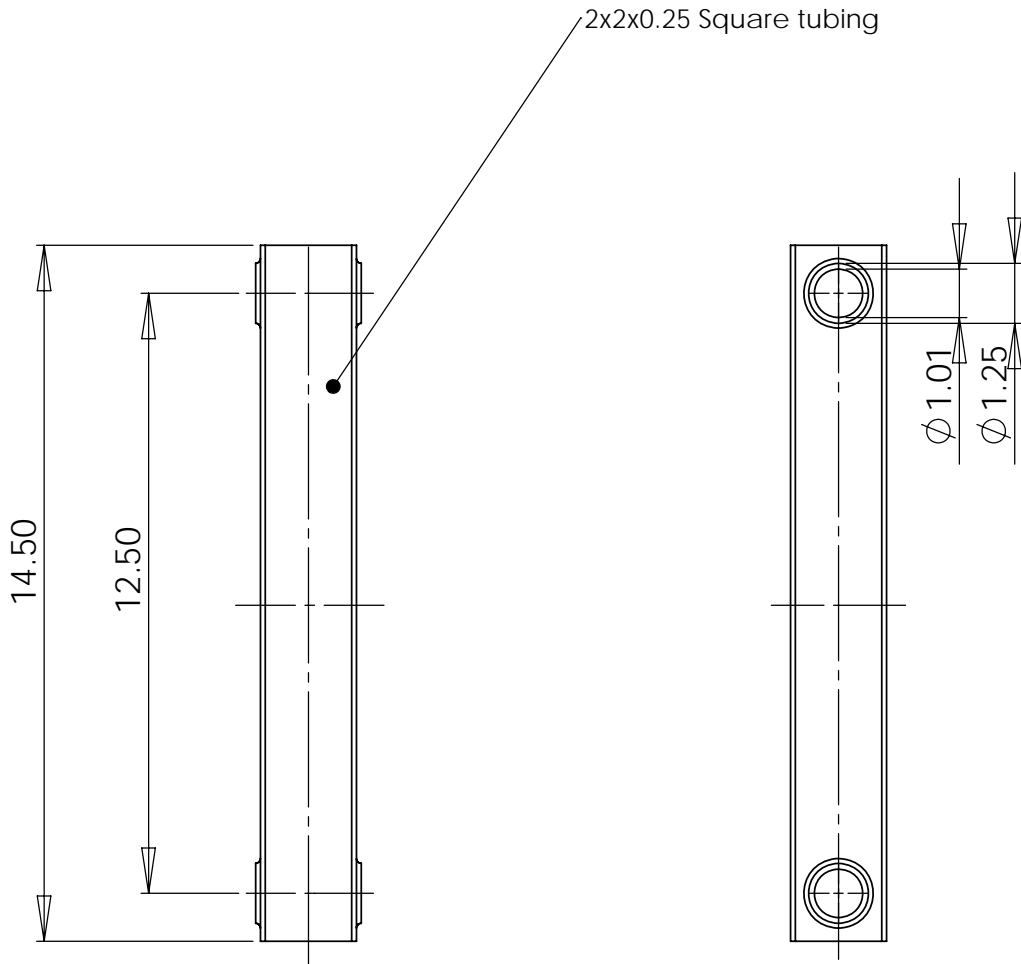

For placing and welding the pipe segments, drill 1-9/32" hole and countersink it, to make room for welding bead.

	NAME	DATE	Queen's University		
DRAWN	D. Matovic	2009/07/27			
CHECKED	D. Matovic	2009/07/27	Main_link_2x2x0.25in		
ENG APPR.					
MFG APPR.					
Q.A.					
COMMENTS:			SIZE	DWG. NO.	REV.
Dimensions are in inches			A		
			SCALE:1:10		SHEET 1 OF 1

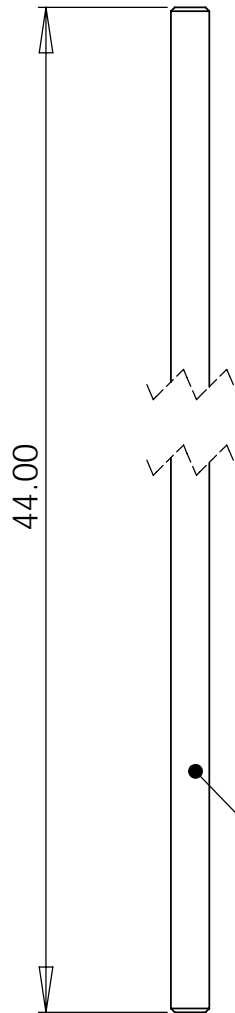

1" Cold rolled round bar

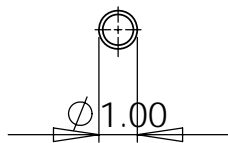

	NAME	DATE	Queen's University		
DRAWN	D. Matovic	2009/07/27			pin_long
CHECKED	D. Matovic	2009/07/27			
ENG APPR.					
MFG APPR.					
Q.A.					
COMMENTS:			SIZE	DWG. NO.	REV.
Dimensions are in inches			A		
			SCALE:1:10		SHEET 1 OF 1

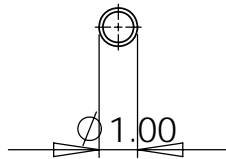
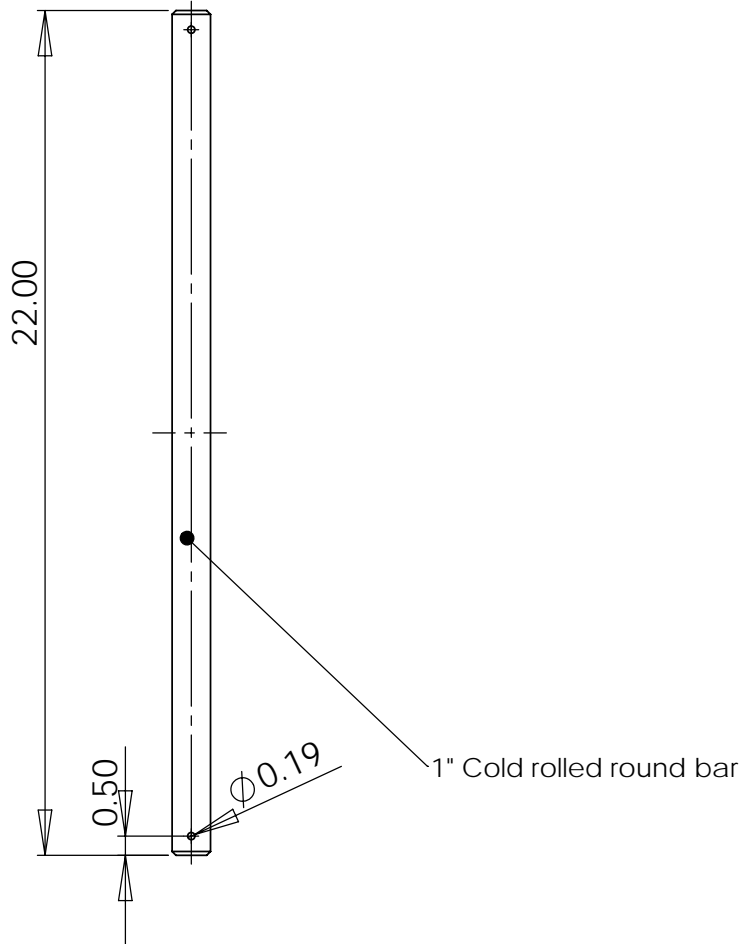

	NAME	DATE	Queen's University		
DRAWN	D. Matovic	2009/07/27			
CHECKED	D. Matovic	2009/07/27	pin_medium		
ENG APPR.					
MFG APPR.					
Q.A.					
COMMENTS:			SIZE	DWG. NO.	REV.
Dimensions are in inches			A		
			SCALE:1:10		SHEET 1 OF 1

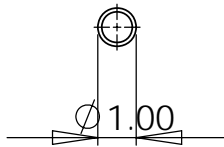
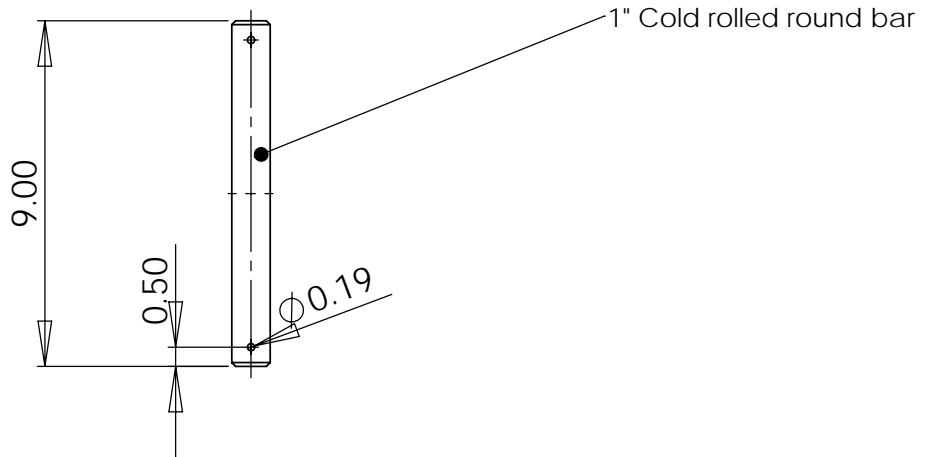

	NAME	DATE	Queen's University		
DRAWN	D. Matovic	2009/07/27			
CHECKED	D. Matovic	2009/07/27	pin_short		
ENG APPR.					
MFG APPR.					
Q.A.					
COMMENTS:			SIZE	DWG. NO.	REV.
Dimensions are in inches			A		
			SCALE:1:5		SHEET 1 OF 1

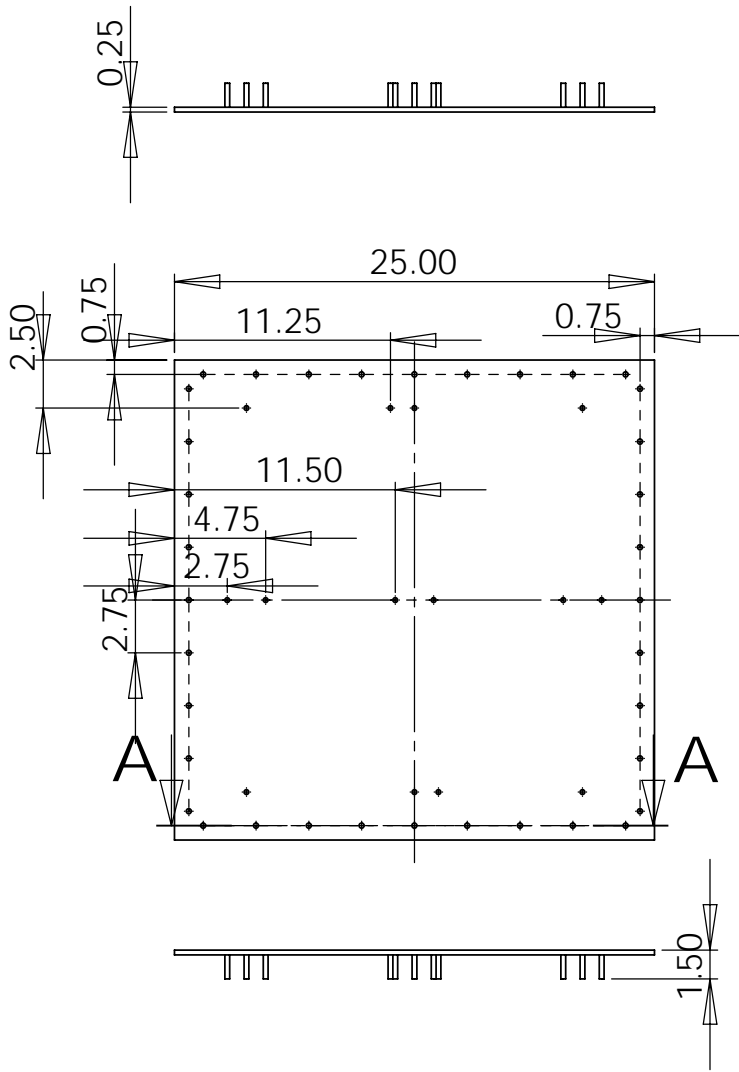

14 1/4"-20 UNC threaded stems
1-1/2" long, welded from behind

SECTION A-A
36 countersunk holes 17/64" dia

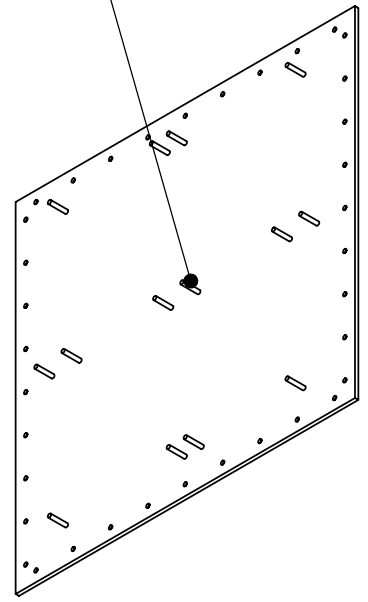

	NAME	DATE	Queen's University plate		
DRAWN	D. Matovic	2009/07/27			
CHECKED	D. Matovic	2009/07/27			
ENG APPR.					
MFG APPR.					
Q.A.					
COMMENTS:			SIZE	DWG. NO.	REV.
Dimensions are in inches			A		
			SCALE:1:10		SHEET 1 OF 1

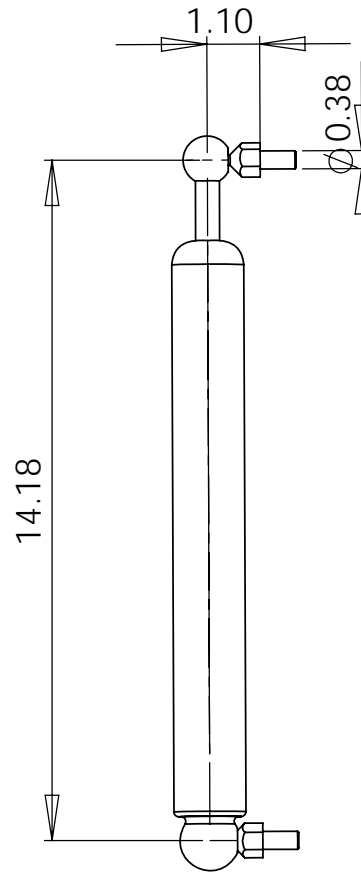

	NAME	DATE	Queen's University		
DRAWN	D. Matovic	2009/07/27			
CHECKED	D. Matovic	2009/07/27	Side_lifter		
ENG APPR.					
MFG APPR.					
Q.A.					
COMMENTS:			SIZE	DWG. NO.	REV.
Dimensions are in inches			A		
			SCALE:1:10		SHEET 1 OF 1

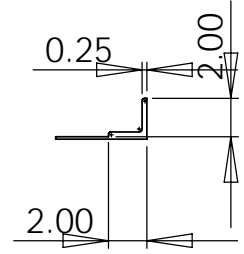
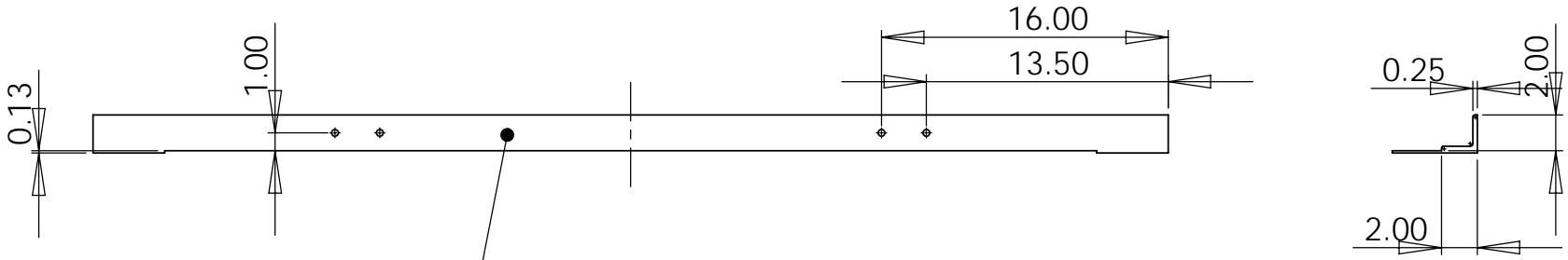
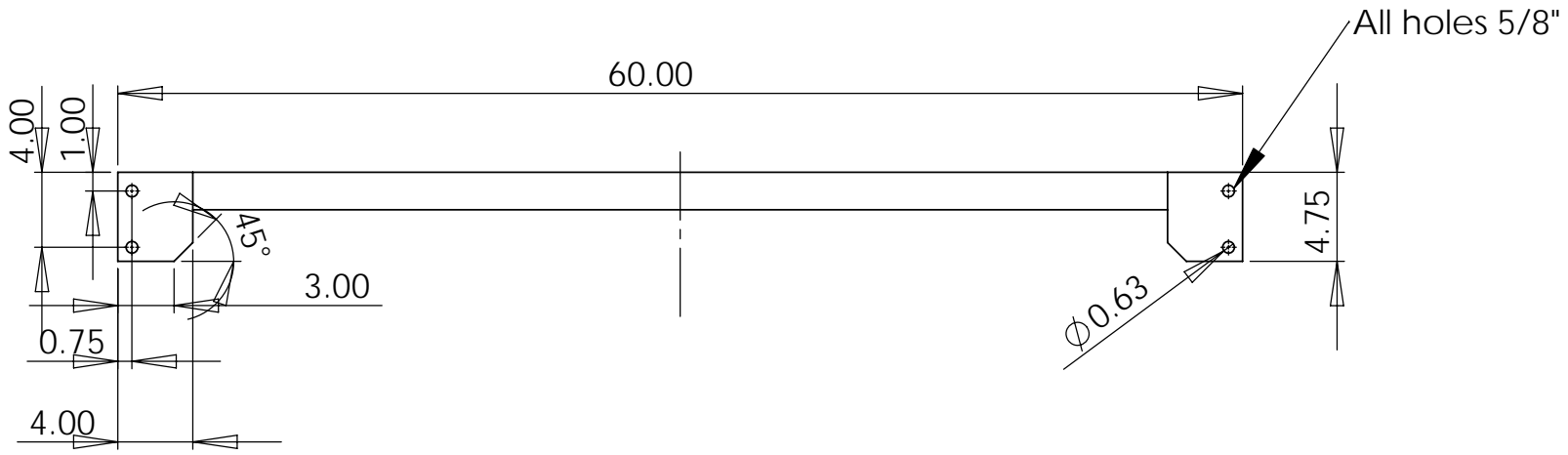

	NAME	DATE	Queen's University		
DRAWN	D. Matovic	2009/07/27			
CHECKED	D. Matovic	2009/07/27	TITLE:		
ENG APPR.			Stand_side_long_L2x2x0.25in		
MFG APPR.					
Q.A.					
COMMENTS:			SIZE	DWG. NO.	REV
Dimensions are in inches			A		
			SCALE: 1:10		SHEET 1 OF 1



		NAME	DATE	Queen's University		
DRAWN		D. Matovic	2009/07/27			TITLE: Stand_side_short_L2x2x0.25in_no_pegs
CHECKED		D. Matovic	2009/07/27			
ENG APPR.						
MFG APPR.						
Q.A.						
COMMENTS: Dimensions are in inches				SIZE A	DWG. NO.	REV
				SCALE: 1:10		SHEET 1 OF 1

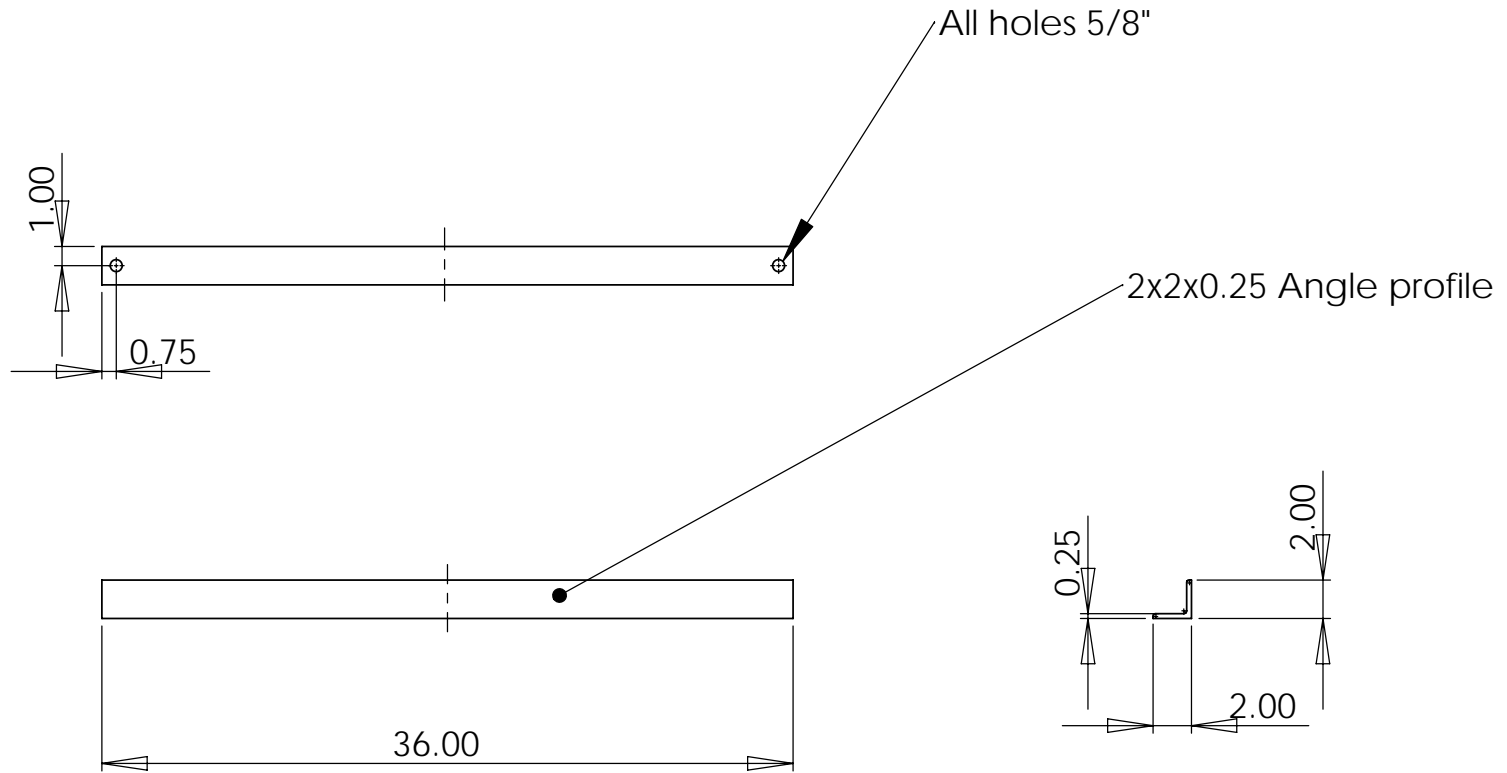

	NAME	DATE	Queen's University		
DRAWN	D. Matovic	2009/07/27			
CHECKED	D. Matovic	2009/07/27	TITLE:		
ENG APPR.			Stand_side_short_L2x2x0.25in_no_pegs		
MFG APPR.					
Q.A.					
COMMENTS:			SIZE	DWG. NO.	REV
Dimensions are in inches			A		
			SCALE: 1:10		SHEET 1 OF 1

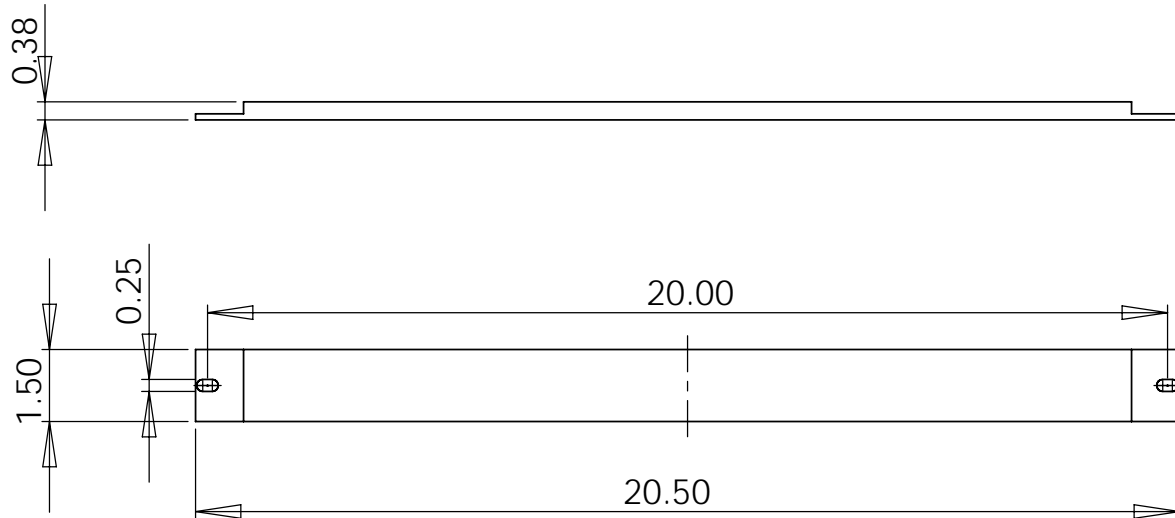
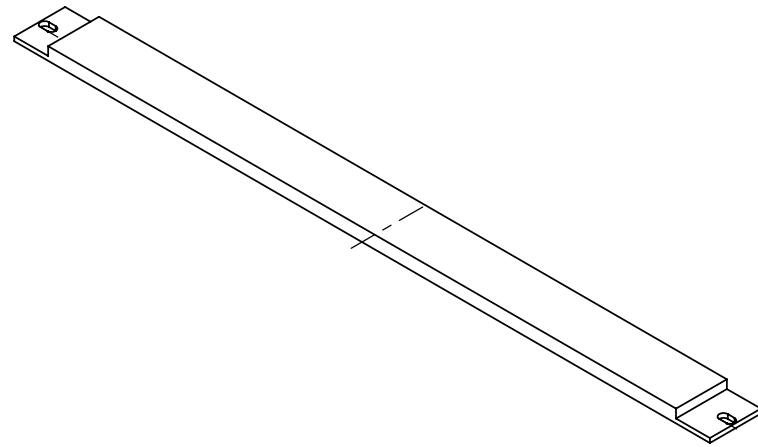

0.25" trimmed at both sides by grinding (original size 21")

	NAME	DATE	Queen's University		
DRAWN	D. Matovic	2009/07/27			
CHECKED	D. Matovic	2009/07/27	TITLE:		
ENG APPR.			Strip_heater		
MFG APPR.					
Q.A.					
COMMENTS:			SIZE	DWG. NO.	REV
Dimensions are in inches			A		
			SCALE: 1:10		SHEET 1 OF 1

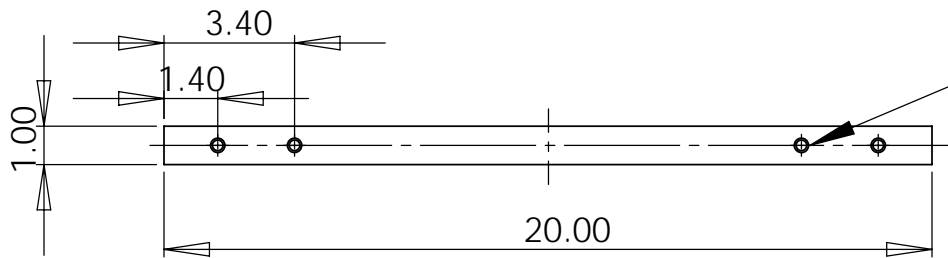

All pins 3/8", 2" long, welded from behind

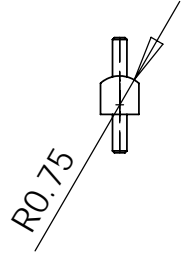
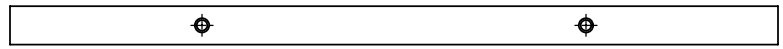
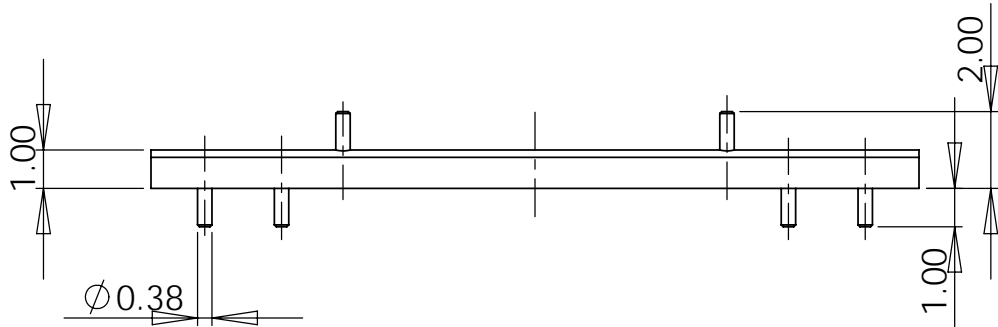

	NAME	DATE	Queen's University		
DRAWN	D. Matovic	2009/07/27			
CHECKED	D. Matovic	2009/07/27	TITLE: support_bar		
ENG APPR.					
MFG APPR.					
Q.A.					
COMMENTS: Dimensions are in inches			SIZE A	DWG. NO.	REV
			SCALE: 1:5		SHEET 1 OF 1

ITEM NO.	PART NUMBER	QTY.
1	Top-weldment	1
2	Gasket-top-one-piece	1
3	Plate_with_heaters	1
4	connector_1_in	4

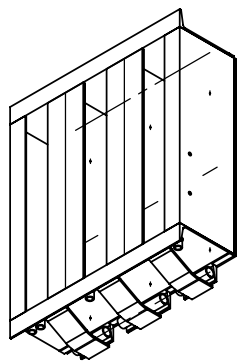
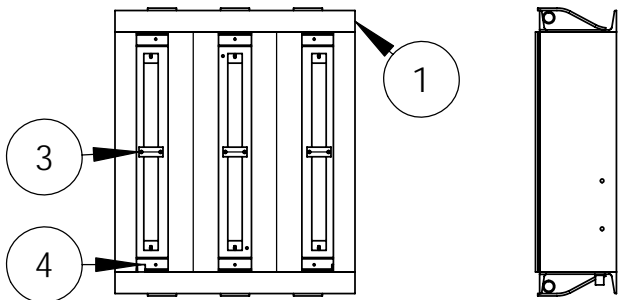
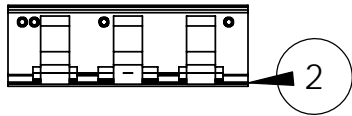

	NAME	DATE	Queen's University		
DRAWN	D. Matovic	2009/07/27			
CHECKED	D. Matovic	2009/07/27	TITLE:		
ENG APPR.			Top-leaf		
MFG APPR.					
Q.A.					
COMMENTS:			SIZE	DWG. NO.	REV
Dimensions are in inches			A		
			SCALE: 1:20		SHEET 1 OF 1

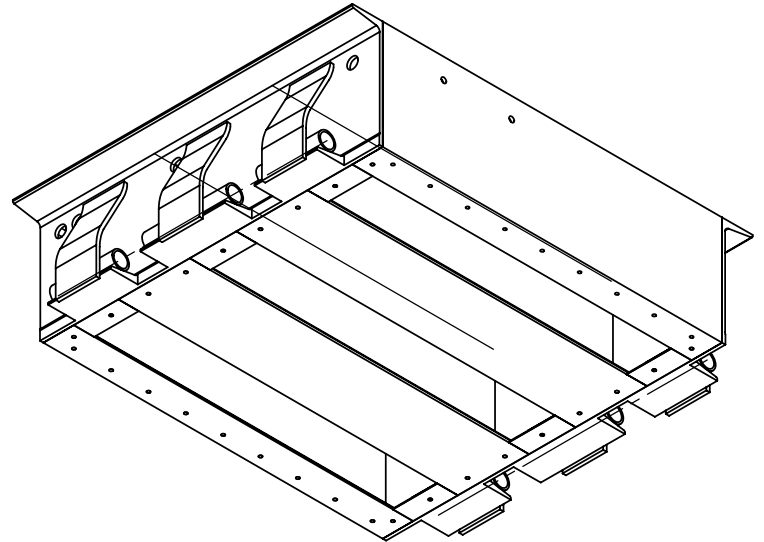
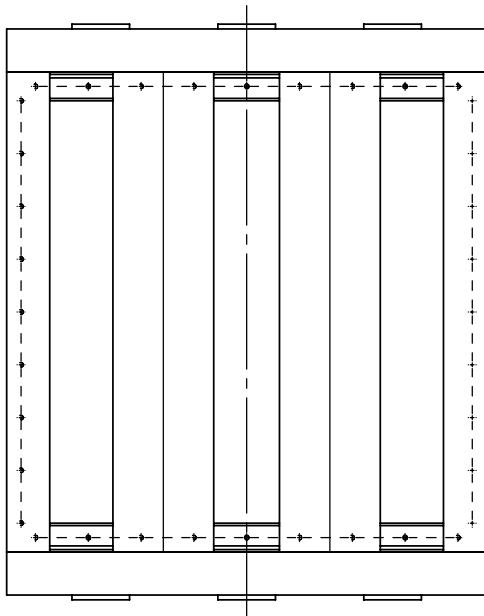
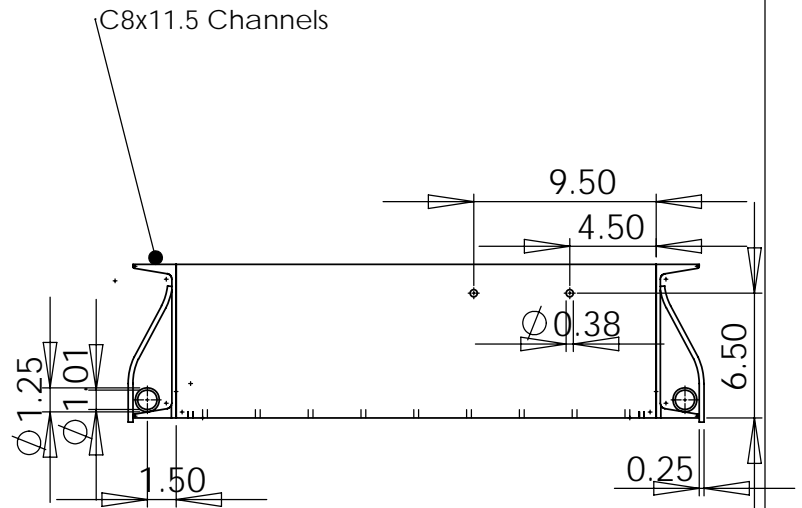
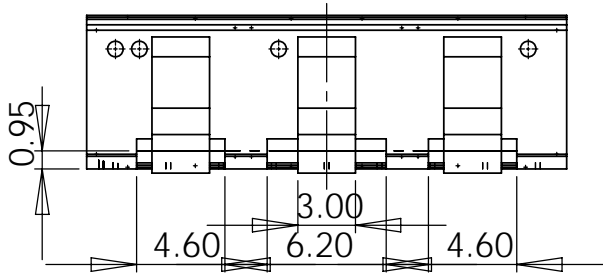
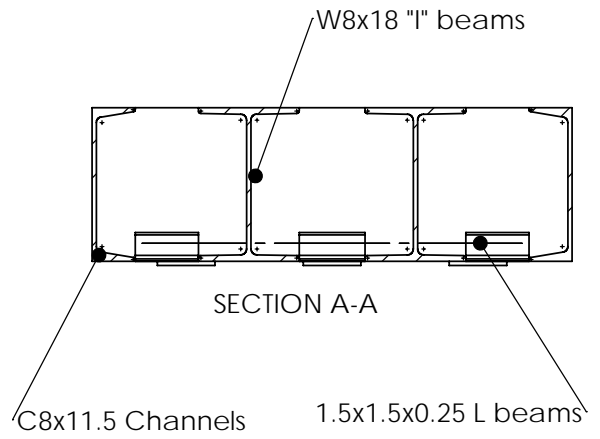
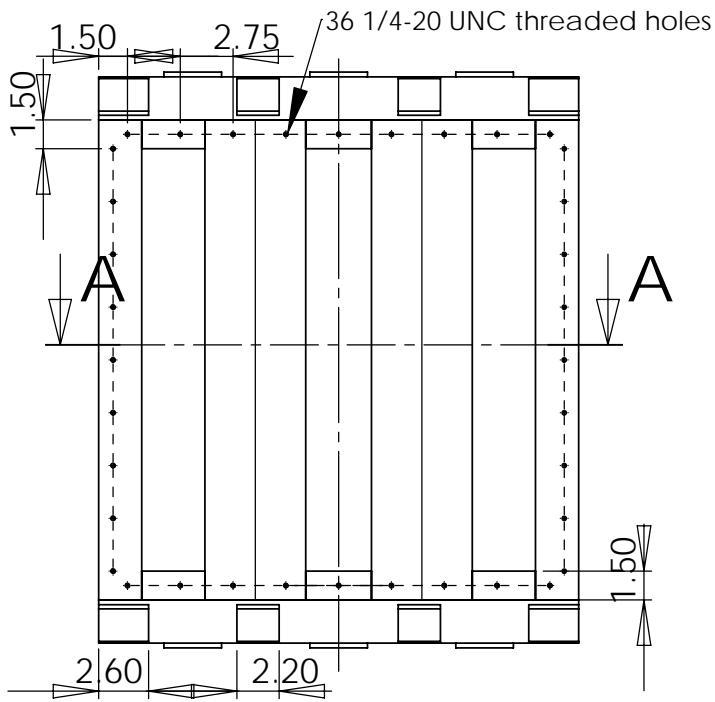

	NAME	DATE
DRAWN	D. Matovic	2009/07/27
CHECKED	D. Matovic	2009/07/27
ENG APPR.		
MFG APPR.		
Q.A.		

COMMENTS:
Dimensions are in inches

Queen's University

Top-weldment

SIZE	DWG. NO.	REV.
A		
SCALE:1:10		SHEET 1 OF 1

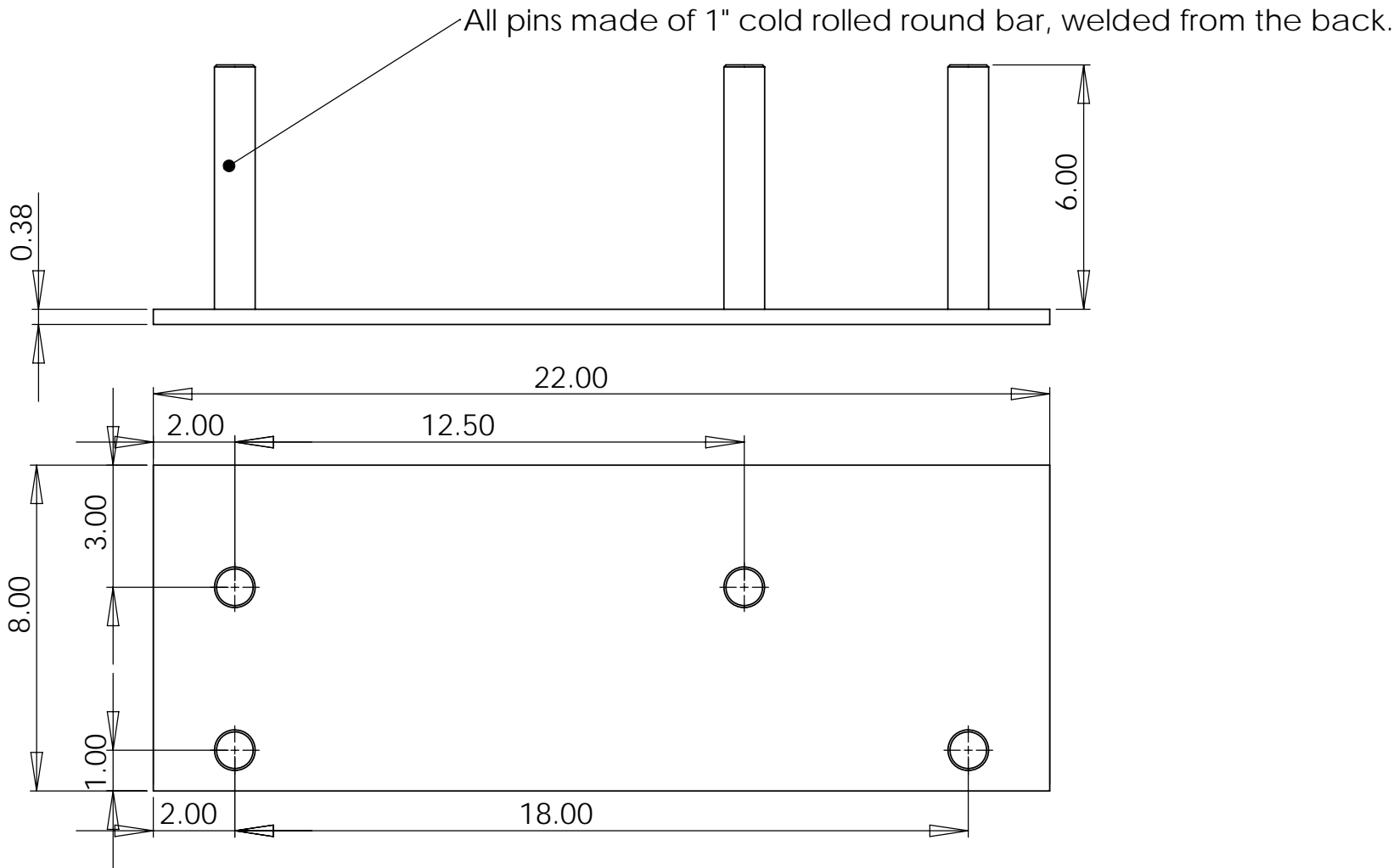

Distance 12.5 in used for main links and leavers.
 Distance 18.0 used for jack holder links.
 A 0.1" shim should be inserted under the main links and jack holding links when put in place, to leave 0.1" pipe protruding on each side.
 For leavers, use 0.25" shims, or as appropriate to keep the pipe protrusions symmetrical.

	NAME	DATE	Queen's University	
DRAWN	D. Matovic	2009/07/27		
CHECKED	D. Matovic	2009/07/27	TITLE: welding_jig	
ENG APPR.				
MFG APPR.				
Q.A.				
COMMENTS: Dimensions are in inches			SIZE A	DWG. NO.
			SCALE: 1:10	REV
				SHEET 1 OF 1

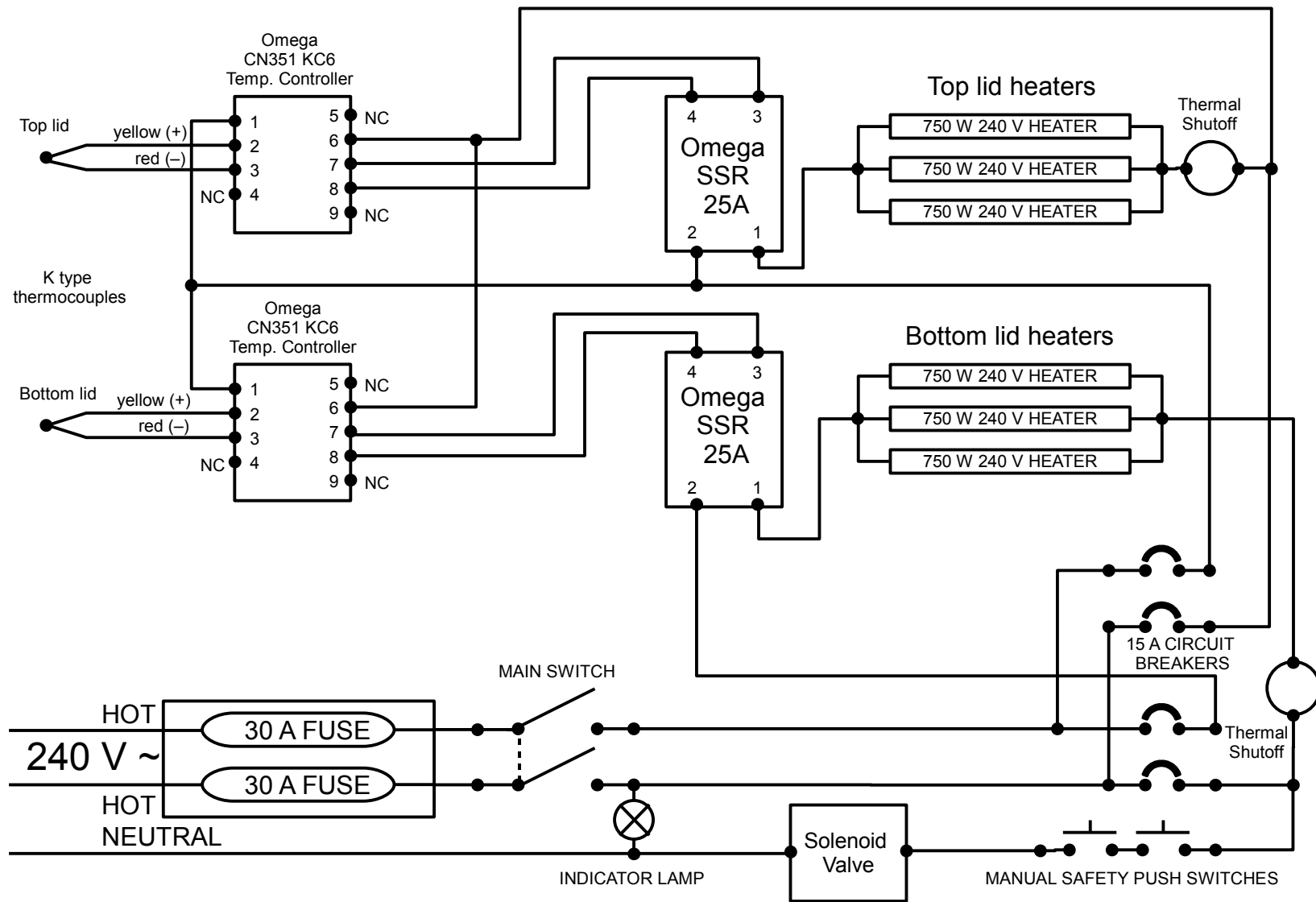

	Date	Name		
Designed, Rev. 1	2008/04/01	Darko Matovic		
Rev. 2	2008/12/01	David Athersych	Kingston Hot Press Wiring Diagram	
Approved		Pierre Chevrier, ESA		



Queen's
University

Kingston Hot Press Prototype 001

Line: Voltage: 240 VAC

Current: 20 A

Power: 4800 W

Short Circuit Rating: 30 A

December
2008